

WSM

WORKSHOP MANUAL
TRACTOR

B2301, B2601

Kubota

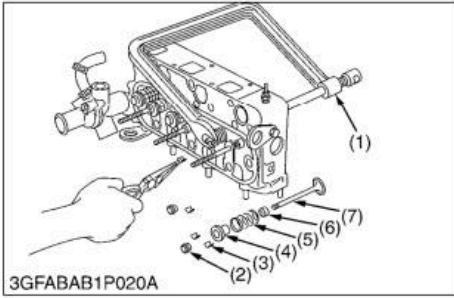

Valves

1. Remove the valve caps (2).
2. Remove the valve spring collet (3), pushing the valve spring retainer (4) by valve spring replacer (1).
3. Remove the valve spring retainer (4), valve spring (5) and valve stem seal (6).
4. Remove the valve (7).

(When reassembling)

- Wash the valve stem seal and valve guide hole, and apply engine oil sufficiently.
- After installing the valve spring collets, lightly tap the stem to assure proper fit with a plastic hammer.

■ IMPORTANT

- **Do not change the combination of valve and valve guide.**

- | | |
|---------------------------|---------------------|
| (1) Valve Spring Replacer | (5) Valve Spring |
| (2) Valve Cap | (6) Valve Stem Seal |
| (3) Valve Spring Collet | (7) Valve |
| (4) Valve Spring Retainer | |

9Y1211338ENS0039US0

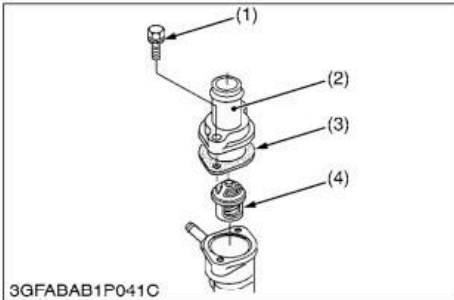

Thermostat Assembly

1. Remove the thermostat cover mounting screws (1), and remove the thermostat cover (2).
2. Remove the thermostat assembly (4).

(When reassembling)

- Apply a liquid gasket (Three Bond 1215 or equivalent) only at the thermostat cover side of the gasket (3).

- | | |
|-------------------------------------|-----------------------------|
| (1) Thermostat Cover Mounting Screw | (3) Thermostat Cover Gasket |
| (2) Thermostat Cover | (4) Thermostat Assembly |

9Y1211338ENS0040US0

(3) Gear Case

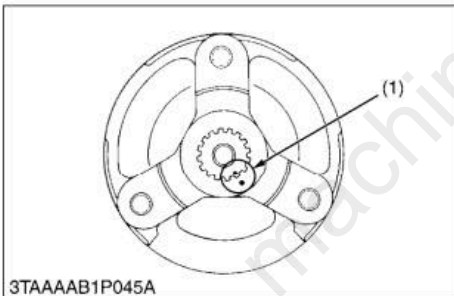

Fan Drive Pulley

1. Secure the flywheel to keep it from turning.
2. Remove the fan drive pulley screw.
3. Draw out the fan drive pulley with a puller.

(When reassembling)

- Install the pulley to the crankshaft, aligning the mark (1) on them.
- Apply engine oil to the fan drive pulley retaining screws. And tighten them.

Tightening torque	Fan drive pulley screw	236 to 245 N·m 24.0 to 25.0 kgf·m 174 to 180 lbf·ft
-------------------	------------------------	---

- (1) Alignment Mark

9Y1211338ENS0041US0

8. DIFFERENTIAL GEAR SYSTEM

[1] DIFFERENTIAL FUNCTION

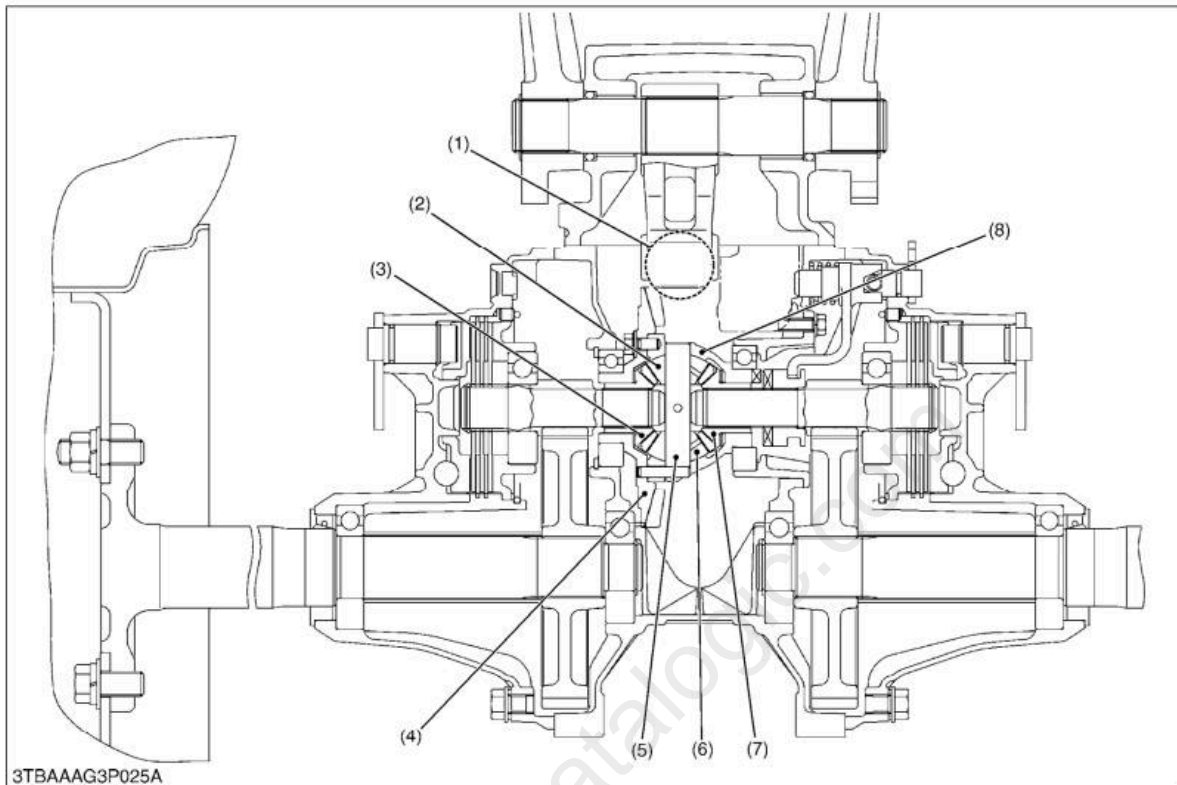

- | | | | |
|-------------------------|----------------------------|-------------------------------|----------------------------|
| (1) Spiral Bevel Pinion | (3) Differential Side Gear | (5) Differential Pinion Shaft | (7) Differential Side Gear |
| (2) Differential Pinion | (4) Spiral Bevel Gear | (6) Differential Pinion | (8) Differential Case |

■ During Straight Running

Rotation of the spiral bevel pinion (1) is transmitted to the spiral bevel gear (4) and differential case (8). When road resistance to the right and left wheels are equal, differential pinions (2), (6) and differential side gears (3), (7) are all rotate as a unit. Both rear axles received equal input, and both wheels turn at the same speed, allowing the tractor to straight ahead. At this time, differential pinions (2), (6) does not rotate around the differential pinion shaft (5).

■ During Turning

When the tractor turns, the road resistance to the inside tire increases (as if braking is applied to that side only). In other words, if one of tires slows down, revolution difference is generated in the differential side gears (3), (7). When rotation of one differential side gear becomes lower than the other, differential pinions (2), (6) begin rotating around differential pinion shaft (5). The other differential side gear is increased in speed by the speed increment of differential pinion shaft (5). This means that rotation of one rear axle is slowed down and that of the other rear axle is increased. Thus, the tractor turns smoothly without power loss.

The combined number of revolutions of the right and left differential side gears is always twice that of the spiral bevel gear (4). When spiral bevel gear revolution is 100 min^{-1} (rpm), and if one of the differential side gears stops moving, the revolution of the other differential side gear becomes 200 min^{-1} (rpm) and if one rotates at 50 min^{-1} (rpm), the other rotates at 150 min^{-1} (rpm).

9Y1211338TRM0024US0

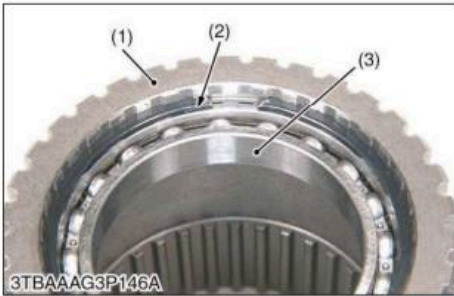

Spline Boss Cir-clip

1. Push the cir-clip with a small screw driver through the small hole of the spline boss (1).
2. Lift the cir-clip (2) with a screw driver not to damage it.

(When reassembling)

- Install the cir-clip (2) holding it by hands.

(1) Spline Boss

(3) Ball Bearing

(2) Cir-clip

9Y1211338TRS0041US0

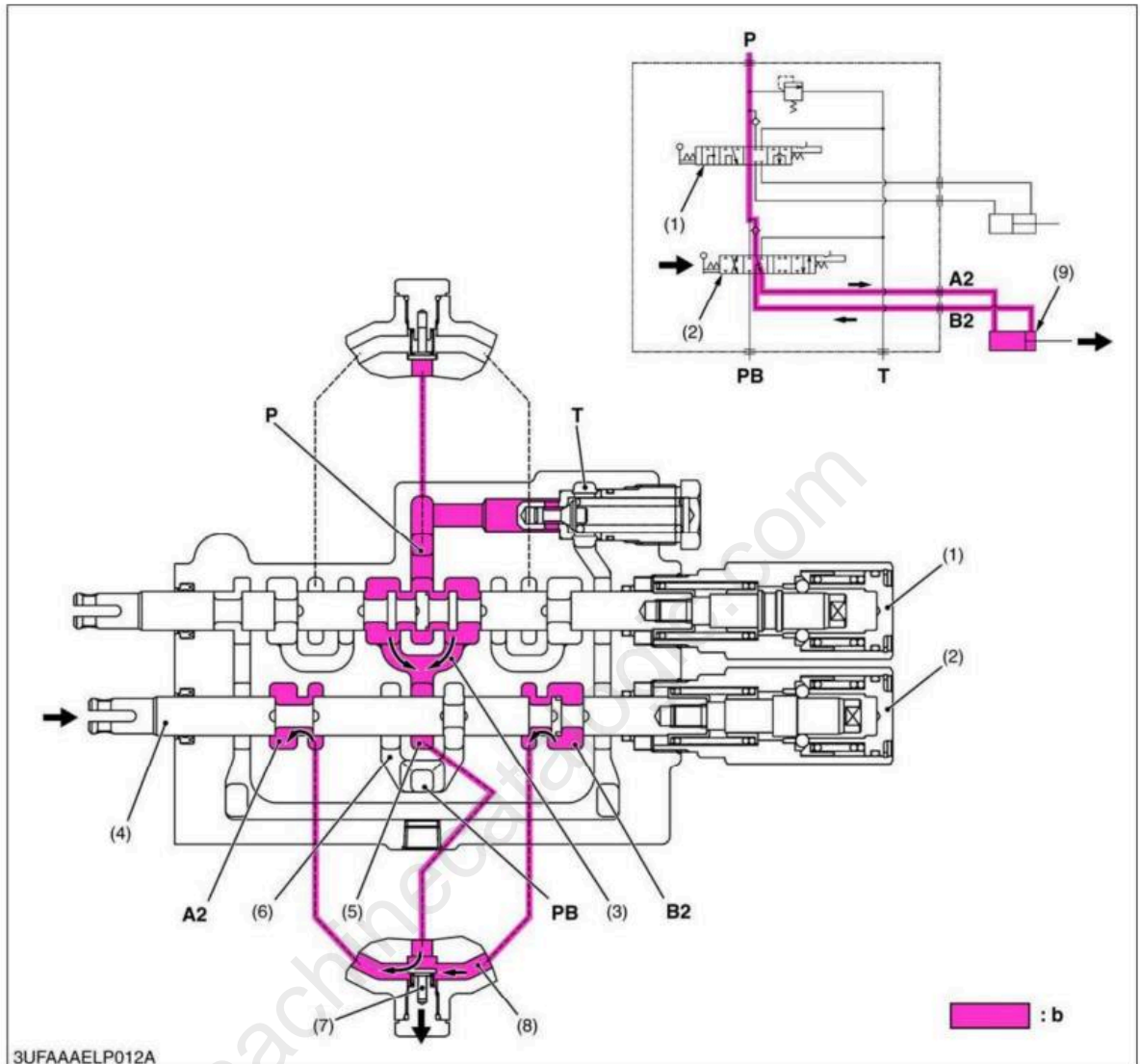

machinecatalogic.com

Dump 1

- (1) Boom Control Section
 (2) Bucket Control Section
 (3) PB Passage 1
 (4) Spool
 (5) Neutral Passage 2

- (6) PB Passage 2
 (7) Load Check Valve
 (8) Passage 2
 (9) Bucket Cylinder

P: P Port
 T: T Port
 PB: PB Port

A2: A2 Port
 (To Bucket Cylinder)
 B2: B2 Port
 (From Bucket Cylinder)
 b: High Pressure

- When the hydraulic control lever is set to the "DUMP 1" position, the spool (4), which forms oil passages among passage 2 (8), A2 port and B2 port.
- The pressure-fed oil from the P port flows through the boom control valve, opens the load check valve, and flows to the bucket cylinder to extend the cylinder through the notched section of the spool and A2 port.
- Return oil from the bucket cylinder (9) flows from the B2 port to the passage 2 (8), and flows to the A2 port together with the pressure-fed oil from the P port. As a result, the dump speed is increased.

(Reference)

- The oil pressure of the A2 port and B2 port is identical, but the bucket cylinder extend by the difference of received pressure area (cylinder rod part).

9Y1211338HYM0017US0

Full Version Available

Kubota B2301 Tractor Workshop Manual

This is a short preview. The complete manual contains all chapters, wiring diagrams, torque specifications and full service procedures.

VIEW THE FULL MANUAL

<https://machinecatalogic.com/kubota-b2301-tractor-workshop-manual/>