

## TO THE READER

This Workshop Manual has been prepared to provide servicing personnel with information on the mechanism, service and maintenance of KUBOTA Tractors B1700, B2100 and B2400. It is divided into two parts, "Mechanism" and "Servicing" for each section.

### ■ Mechanism

Information on the construction and function are included. This part should be understood before proceeding with troubleshooting, disassembling and servicing.

### ■ Servicing

Under the heading "General" section comes general precautions, check and maintenance and special tools. Other section, there are troubleshooting, servicing specification lists, checking and adjusting, disassembling and assembling, and servicing which cover procedures, precautions, factory specifications and allowable limits.

All information, illustrations and specifications contained in this manual are based on the latest production information available at the time of publication.

The right is reserved to make changes in all information at any time without notice.

March '95

© KUBOTA Corporation 1995

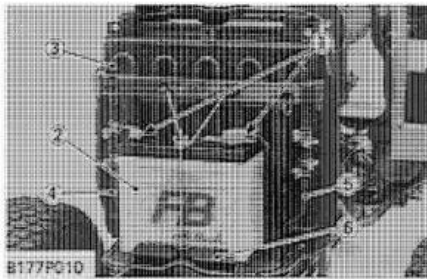

B1779010

### Battery, Oil Cooler and Hydraulic Pipes (HST Type)

1. Disconnect the battery cords (1) and dismantle the battery (2).
2. Loosen the clamps and remove the battery base (6) with oil cooler (3) then remove the delivery pipe (4) and return pipe (5).

#### NOTE

- When disconnecting the battery cords, disconnect the grounding cord first. When connecting the positive cord first.

(1) Battery Cord

(2) Battery

(3) Oil Cooler

(4) Delivery Pipe

(5) Return Pipe

(6) Battery Base

### Steering Wheel

1. Remove the steering wheel cap.
2. Remove the steering wheel mounting nut and remove the steering wheel with a steering wheel puller. (Code No : 07916-51090)

#### (When reassembling)

Tightening torque	Steering wheel mounting nut	29.4 to 49.0 N·m 3.0 to 5.0 kgf·m 21.7 to 36.2 ft·lbs

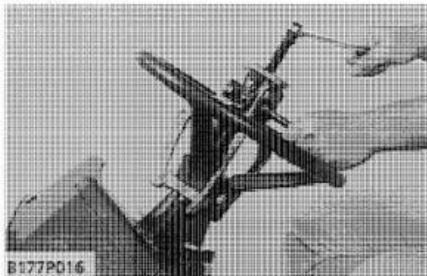

B1779016

### Meter Panel and Panel Under Cover

1. Remove the meter panel (2) and disconnect the meter panel connector (3) and hour-meter cable (7) from the meter panel. Then remove the meter panel.
2. Tap out the spring pin and remove the hand accelerator lever (1).
3. Disconnect the combination switch connector (4) and main switch connector (5).
4. Remove the panel under cover mounting screw and remove the panel under cover (6).

(1) Hand Accelerator Lever

(2) Meter Panel

(3) Meter Panel Connector

(4) Combination Switch Connector

(5) Main Switch Connector

(6) Panel Under Cover

(7) Hour-meter Cable

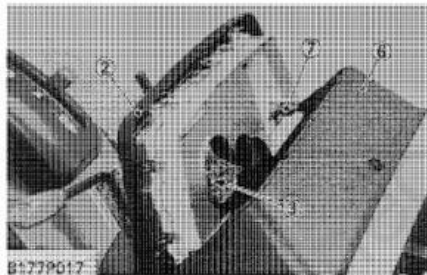

B1779017

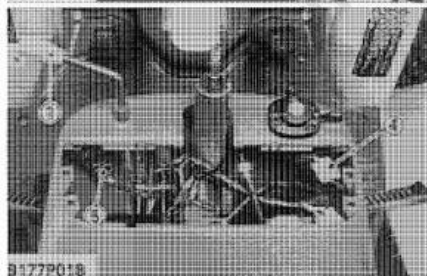

B1779018

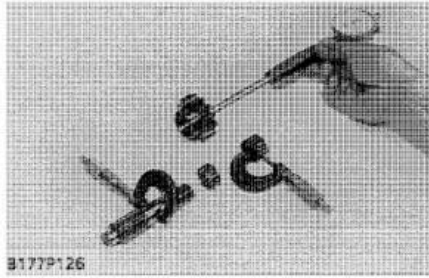

B177P126

#### Clearance between Gear and Shaft

1. Measure the gear I.D. with a cylinder gauge, and then shaft O.D. with an outside micrometer.
2. Measure the O.D. of two needles in the needle bearing with an outside micrometer.
3. Clearance is the difference between the gear I.D. and the sum of shaft O.D. and two needles O.D..
4. If the clearance exceeds the allowable limit, replace it.

Clearance between F.W.D. shaft and 16T-20T gear	Factory spec.	0.027 to 0.067 mm 0.0011 to 0.0025 in.
	Allowable limit	0.10 mm 0.0039 in.
F.W.D. shaft O.D.	Factory spec.	21.967 to 21.980 mm 0.8648 to 0.8654 in.
16T-20T gear I.D.	Factory spec.	28.007 to 28.021 mm 1.1024 to 1.1032 in.
Needle O.D.	Factory spec.	2.996 to 3.000 mm 0.1179 to 0.1181 in.

Clearance between 13T gear and 3rd shaft	Factory spec.	0.007 to 0.046 mm 0.0003 to 0.0018 in.
	Allowable limit	0.10 mm 0.0039 in.
3rd shaft O.D.	Factory spec.	21.987 to 22.000 mm 0.8656 to 0.8661 in.
13T gear I.D.	Factory spec.	28.007 to 28.021 mm 1.1026 to 1.1032 in.
Needle O.D.	Factory spec.	2.994 to 3.000 mm 0.1179 to 0.1181 in.

Clearance between 11T gear, one-way clutch cam and mid-PTO shaft	Factory spec.	0.020 to 0.026 mm 0.0008 to 0.0010 in.
	Allowable limit	0.10 mm 0.0039 in.
Mid-PTO shaft O.D.	Factory spec.	19.989 to 20.000 mm 0.7869 to 0.7874 in.
11T gear and one-way clutch I.D.	Factory spec.	24.007 to 24.020 mm 0.9452 to 0.9457 in.
Needle O.D.	Factory spec.	1.997 to 2.000 mm 0.0786 to 0.0787 in.

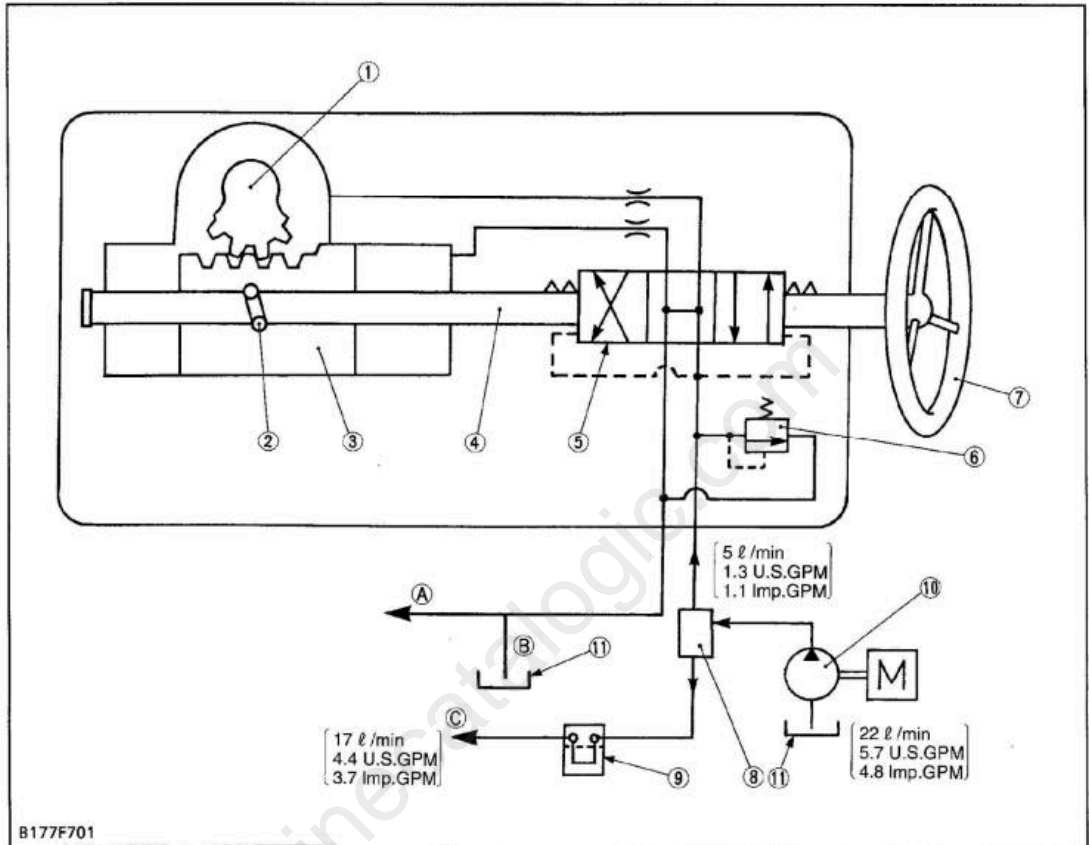
**[1] HYDRAULIC CIRCUIT FOR POWER STEERING SYSTEM**

(A) To Oil Cooler (HST Type Only)

(B) To Transmission (Manual Transmission Type Only)

(C) To Control Valve

(1) Sector Gear Shaft

(4) Worm Shaft

(7) Steering Wheel

(10) Pump

(2) Balls

(5) Sliding Valve

(8) Flow Priority Valve

(11) Transmission Case

(3) Ball Nut

(6) Relief Valve

(9) Hydraulic Block Type  
Outlet

All models are available to be equipped with integral type power steering that of sliding valve with centering spring type.

Flow priority valve (8) divides the oil fed to hydraulic block type outlet (9) into two directions. One is the control flow to power steering (constantly 5 l/min., 1.3 U.S.GPM, 1.1 Imp.GPM at any engine speed). And the other is excessive flow to control valve.

The mechanical gear section shown in the next page operates in the same way as ordinary manual steering systems. However, with power steering, the worm shaft (4) is supported only by the centering springs (13).

When the worm thrust force (turning force of the ball screw section) exceeds centering spring setting load, the worm shaft (4) axially shifts by a specified displacement (Stroke: about 0.4 mm (0.016 in.)). When a load is applied to tires and worm thrust force required for operation is greater than the centering spring setting load, turning the steering wheel does not rotate the sector gear shaft (1), but rather axially moves the worm shaft (4). The valve spool (19), fixed on the worm shaft (4) by the nut (21), changes the condition of the three-position, four-way open center (all ports open) valve (5) by sliding in the valve housing (20), to generate pressure as required.

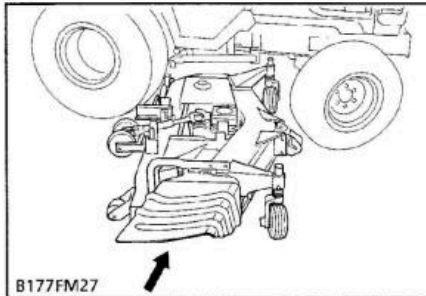

B177FM27

### Setting Mower

1. Turn the steering wheel fully left.
2. Install the mower from right side of the tractor.
3. Roll the mower under the tractor, and then return the steering wheel.

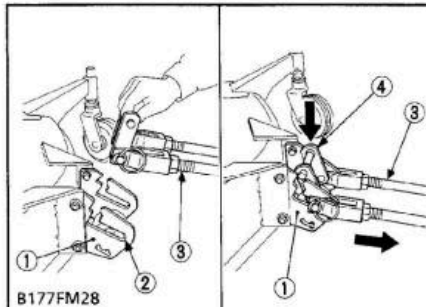

B177FM28

### Front Link

1. Hook the front link (3) with the clevis pin section to front end of the groove (2), and then turn the stopper (4) as shown in the figure.

### (Reference)

- Make sure the length (L) of the front link (3) is as follows.  
 RC54-24B : 505 mm (19.9 in.)  
 RC60-24B : 500 mm (19.7 in.)

- |            |                |
|------------|----------------|
| (1) Stay   | (3) Front Link |
| (2) Groove | (4) Stopper    |

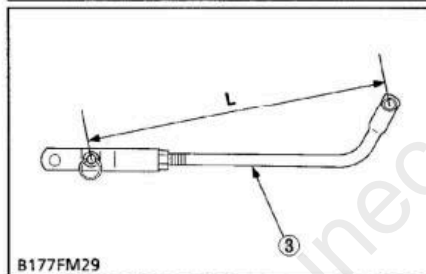

B177FM29

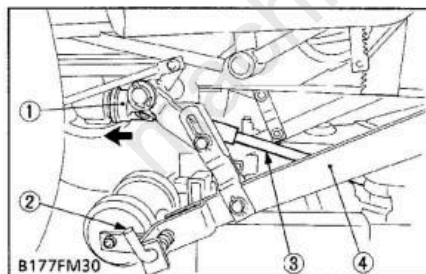

B177FM30

### Mounting Universal Joint and Rear Link

1. Pull back the coupler (1) of the universal joint.
2. Push the universal joint (3) onto the mid PTO shaft, and release the coupler (1).
3. Slide the universal joint back and forward to make sure the universal joint is locked securely.
4. Lower the rear links.
5. Attach the rear links (4) to the mower deck, pulling the L-pins (2).

- |             |                     |
|-------------|---------------------|
| (1) Coupler | (3) Universal Joint |
| (2) L-pin   | (4) Rear Link       |

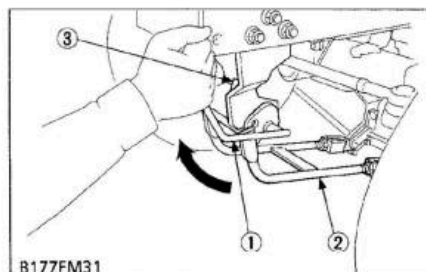

B177FM31

### Mounting Front Link

1. Push down the link fixing lever, pulling the L-pin.
2. Hook the front link (2) to the lever fulcrum, and turn the link fixing lever (1).
3. Return the L-pin (3).

### NOTE

- Make sure the link fixing lever (1) is fixed with L-pin (3) securely.

- |                       |           |
|-----------------------|-----------|
| (1) Link Fixing Lever | (3) L-pin |
| (2) Front Link        |           |

# Full Version Available

Kubota B2400 Tractor Workshop Manual

This is a short preview. The complete manual contains all chapters, wiring diagrams, torque specifications and full service procedures.

**VIEW THE FULL MANUAL**

<https://machinecatalogic.com/kubota-b2400-tractor-workshop-manual/>