

TO THE READER

This Workshop Manual has been prepared to provide servicing personnel with information on the mechanism, service and maintenance of KUBOTA Tractor B2410, B2710 and B2910. It is divided into two parts, "Mechanism" and "Servicing" for each section.

■ Mechanism

Information on the construction and function are included. This part should be understood before proceeding with troubleshooting, disassembling and servicing.

■ Servicing

Under the heading "General" section comes general precautions, check and maintenance and special tools. Other section, there are troubleshooting, servicing specification lists, checking and adjusting, disassembling and assembling, and servicing which cover procedures, precautions, factory specifications and allowable limits.

All information, illustrations and specifications contained in this manual are based on the latest production information available at the time of publication.

The right is reserved to make changes in all information at any time without notice.

© KUBOTA Corporation 2000

February 2000

12271Z00010

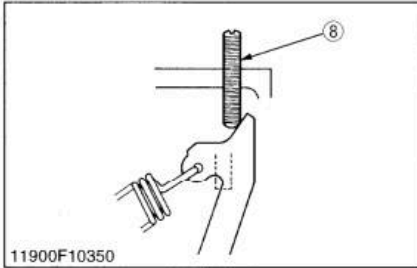
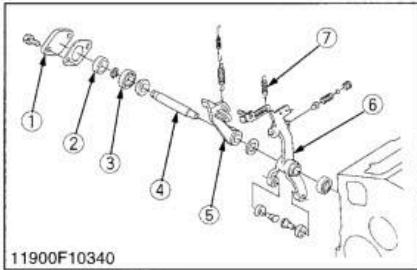
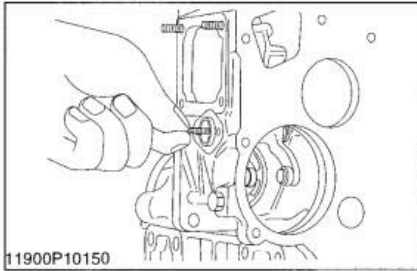

Fork Lever

[For V1305-E2 and V1505-E2]

- Do not remove the maximum torque limiter.
- Fork lever component can not remove because of the maximum torque limiter.

[Others]

1. Remove the start spring (7).
2. Remove the fork lever shaft cover (1).
3. Pull out the fork lever shaft (4), and remove the spacer (2), bearing (3), fork levers 1 (6) and 2 (5).

(When reassembling)

- Apply a liquid gasket (Three Bond 1215 or equivalent) to the both sides of the fork lever shaft cover, and fit the fork lever shaft cover with the "UP" mark facing upwards.
- Securely fit the start spring.

■ IMPORTANT

- Install the fork lever 2 (5) to position it on the right side of the maximum output limit bolt (8) as shown in the figure.

- | | |
|----------------------------|-------------------------------|
| (1) Fork Lever Shaft Cover | (5) Fork Lever 2 |
| (2) Spacer | (6) Fork Lever 1 |
| (3) Bearing | (7) Start Spring |
| (4) Fork Lever Shaft | (8) Maximum Output Limit Bolt |

11900S10160

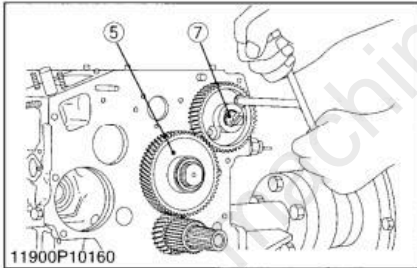

Camshaft and Idle Gear 1, 2

1. Remove the external snap ring, and then remove the idle gear 1 (5) and the idle gear 2 (3).
2. Remove the camshaft stopper mounting screw, and pull out the camshaft (7).

(When reassembling)

- When installing the idle gear 1, be sure to align the alignment marks (a), (b), (c) on the gears.
- Securely fit the external snap ring and stopper.

- | | |
|--------------------------------|--|
| (1) Injection Pump Gear | (a) Alignment Mark (Idle Gear 1 and Cam Gear) |
| (2) Governor Gear | (b) Alignment Mark (Idle Gear 1 and Crank Gear) |
| (3) Idle Gear 2 (V1305, V1505) | (c) Alignment Mark (Idle Gear 1 and Injection Pump Gear) |
| (4) Crank Gear | |
| (5) Idle Gear 1 | |
| (6) Cam Gear | |
| (7) Camshaft | |

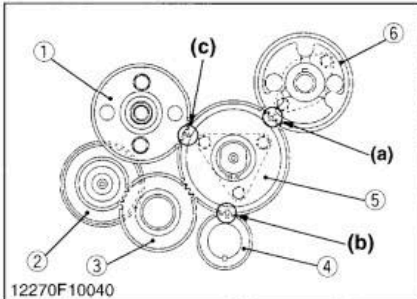

■ IMPORTANT

- There is a model of idle gear 1 (5) and idle gear 2 (3) by the difference of the method of transmission the power to the governor gear (2).

12271S10170

■ Charge Relief Valve

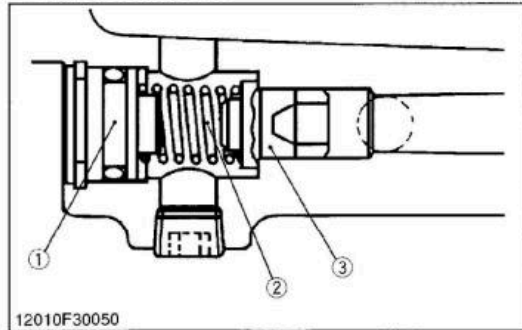

While pumped and filtered oil flows into the main oil circuit through the check and high pressure relief valves, and excessive oil passes to the housing through the charge relief valve.

Oil temperature	Valve operating pressure
50 °C (122 °F)	500 to 800 kPa 5.1 to 8.2 kgf/cm ² 73 to 116 psi

- (1) Plug
- (2) Spring
- (3) Charge Relief Poppet

12270M30030

■ Check and High Pressure Relief Valve

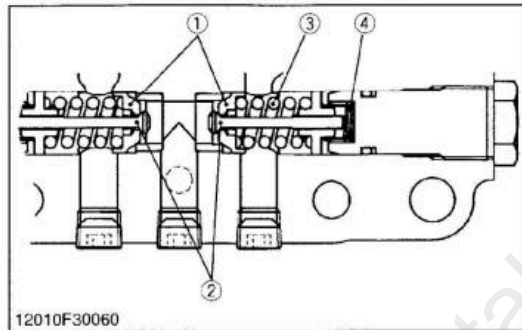

The check and high pressure relief valves monitor the oil pressure in each line of the main oil circuit.

In neutral, both valves are open and charging oil enters into the main oil circuit through the valves.

At normal operation, the check valve in the high pressure side is closed and it pushes and opens the another one.

When excessively high pressure is built up in one line, the high pressure relief valve located in this line is open and the oil flows into another line.

Oil temperature	Valve operating pressure
50 °C (122 °F)	30.9 to 31.9 MPa 315 to 325 kgf/cm ² 4480 to 4622 psi

- (1) Check Valve Seat
- (2) Relief Poppet
- (3) Relief Spring
- (4) Check Spring

12270M30040

■ Neutral Valve

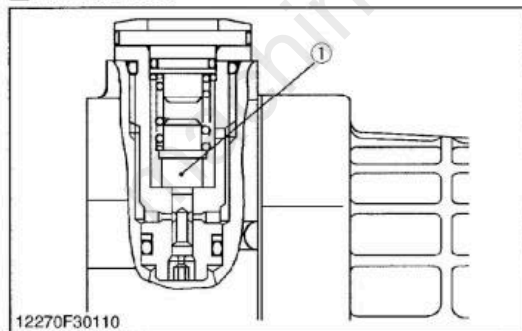

The neutral valves in the main oil circuit lines are open and pass the oil to the case when in neutral, and the oil pressure in their lines becomes low. And when the oil pressure in the high pressure line increases to a specified pressure, the neutral valve closes.

Oil temperature	Valve operating pressure	
50 °C (122 °F)	Close	7.36 to 9.81 MPa 75 to 100 kgf/cm ² 1067 to 1422 psi
	Open	1.47 to 2.45 MPa 15 to 25 kgf/cm ² 213 to 356 psi

- (1) Neutral Valve

12270M30050

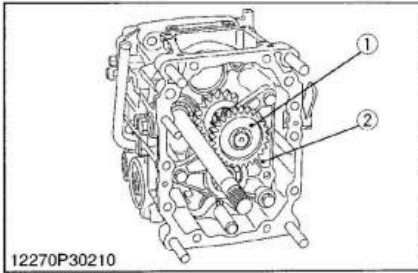

12270P30210

Bearing Holder

1. Remove the external snap ring and remove the 27T gear (1).
2. Remove the bearing holder mounting screws and remove the bearing holder (2).

(When reassembling)

Tightening torque	Bearing holder mounting screw	50 to 55 N·m 5.1 to 5.6 kgf·m 36.9 to 40.1 ft·lbs
-------------------	-------------------------------	---

(1) 27T Gear

(2) Bearing Holder

12270S30240

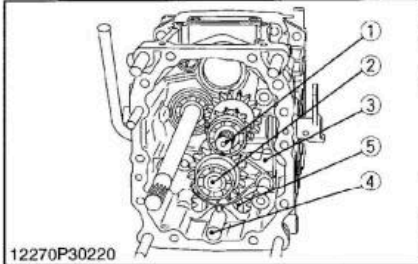

12270P30220

2nd Gear Shaft and Middle Shaft

1. Remove the 2nd gear shaft (1) with bearings.
2. Remove the 3rd shaft assembly (2) and shift fork (3) with shift rod.
3. Remove the middle shaft (4) and 19T gear (5) with bearing.

(When reassembling)

- When assembling the 19T gear (5), face the chamfer side to the rear.

(1) 2nd Gear Shaft

a : Front

(2) 3rd Shaft Assembly

b : Rear

(3) Shift Fork

(4) Middle Shaft

(5) 19T Gear

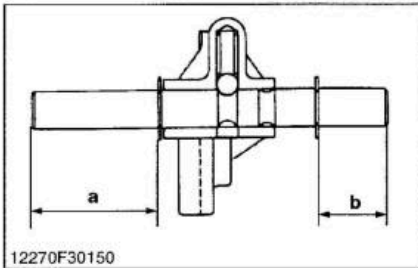

12270F30150

12270S30250

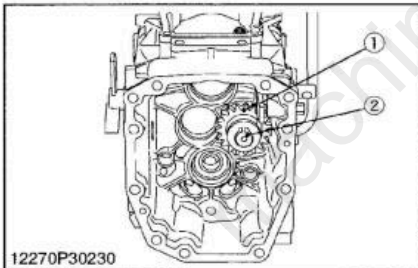

12270P30230

Front Wheel Drive Shaft

1. Remove the external snap ring and remove the 20T shifter gear (1).
2. Draw out the front wheel drive shaft (2) to the front.

(1) 20T Shifter Gear

(2) Front Wheel Drive Shaft

12270S30260

8 HYDRAULIC SYSTEM

machinecatalogic.com

Full Version Available

Kubota B2710 Tractor Workshop Manual

This is a short preview. The complete manual contains all chapters, wiring diagrams, torque specifications and full service procedures.

VIEW THE FULL MANUAL

<https://machinecatalogic.com/kubota-b2710-tractor-workshop-manual/>