

# WSM

---

WORKSHOP MANUAL  
**TRACTOR**

**B3000-AUS**

---

**Kubota**

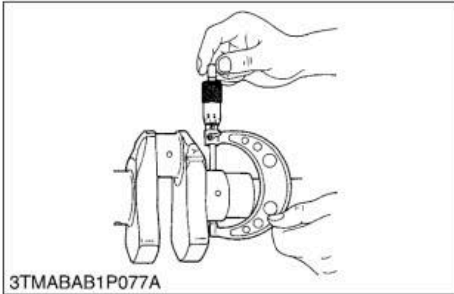

3TMABAB1P077A

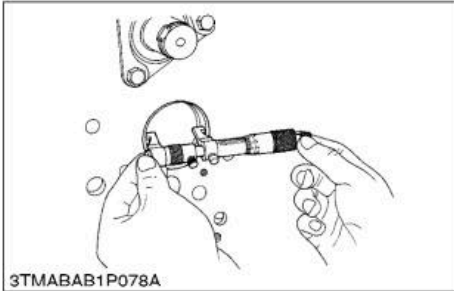

3TMABAB1P078A

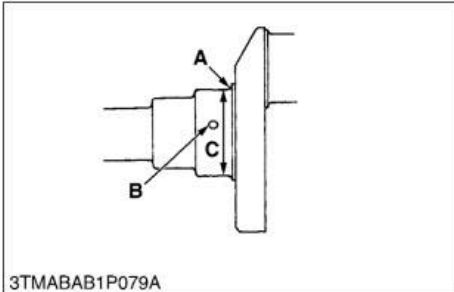

3TMABAB1P079A

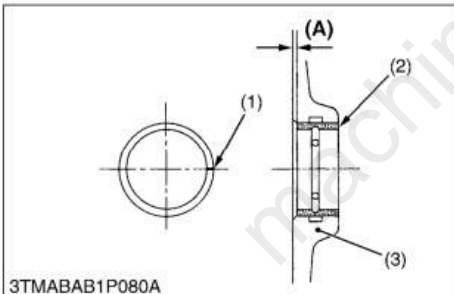

3TMABAB1P080A

### Oil Clearance between Crankshaft Journal and Crankshaft Bearing 1

1. Measure the O.D. of the crankshaft front journal with an outside micrometer.
2. Measure the I.D. of the crankshaft bearing 1 with an inside micrometer, and calculate the oil clearance.
3. If the clearance exceeds the allowable limit, replace the crankshaft bearing 1.
4. If the same size bearing is useless because of the crankshaft journal wear, replace it with an undersize one referring to the table and figure.

Oil clearance between crankshaft journal and crankshaft bearing 1	Factory specification	0.034 to 0.114 mm 0.0013 to 0.0045 in.
	Allowable limit	0.20 mm 0.0079 in.

Crankshaft journal O.D.	Factory specification	47.934 to 47.950 mm 1.8872 to 1.8877 in.
Crankshaft bearing 1 I.D.	Factory specification	47.984 to 48.048 mm 1.8892 to 1.8916 in.

### (Reference)

- Undersize dimensions of crankshaft journal

Undersize	0.20 mm 0.0079 in.	0.4 mm 0.016 in.
Dimension A	2.3 to 2.7 mm radius 0.091 to 0.106 in. radius	2.3 to 2.7 mm radius 0.091 to 0.106 in. radius
Dimension B	1.0 to 1.5 mm relief 0.040 to 0.059 in. relief	1.0 to 1.5 mm relief 0.040 to 0.059 in. relief
Dimension C	47.734 to 47.750 mm dia. 1.8793 to 1.8799 in. dia.	47.534 to 47.550 mm dia. 1.8715 to 1.8720 in. dia.

The crankshaft journal must be fine-finished to higher than  $R_{max}=0.8S$ .

9Y1210623ENS0084US0

### Replacing Crankshaft Bearing 1

#### (When removing)

1. Press out the used crankshaft bearing 1 using a crankshaft bearing 1 replacing tool. (Refer to G-47.)

#### (When installing)

1. Clean a new crankshaft bearing 1 and crankshaft journal bore, and apply engine oil to them.
2. Using a crankshaft bearing 1 replacing tool, press in a new bearing 1 (2) so that its seam (1) directs toward the exhaust manifold side. (See figure.)

Dimension (A)	Factory specification	0 to 0.3 mm 0 to 0.01 in.
---------------	-----------------------	------------------------------

(1) Seam

(3) Cylinder Block

(2) Crankshaft Bearing 1

9Y1210623ENS0085US0

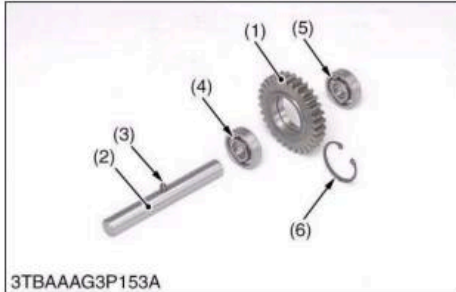
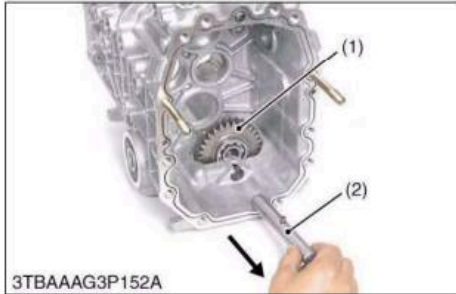
**(9) Mid-PTO Section****Mid-gear and Idle Shaft**

1. Remove the idle shaft (2) from the transmission case using a screw driver.
2. Remove the mid-gear (1) from the transmission case.
3. Remove the ball bearings (4) (5) and the internal cir-clip (6) from the mid-gear (1).

**(When reassembling)**

- Install the internal cir-clip (6) to the inner groove of the mid-gear (1) securely.

- (1) 30T Mid-gear
- (2) Idle Shaft
- (3) Spring Pin

- (4) Ball Bearing
- (5) Ball Bearing
- (6) Internal Cir-clip

9Y1210623TRS0043US0



## [2] DISASSEMBLING AND ASSEMBLING

### (1) Starter

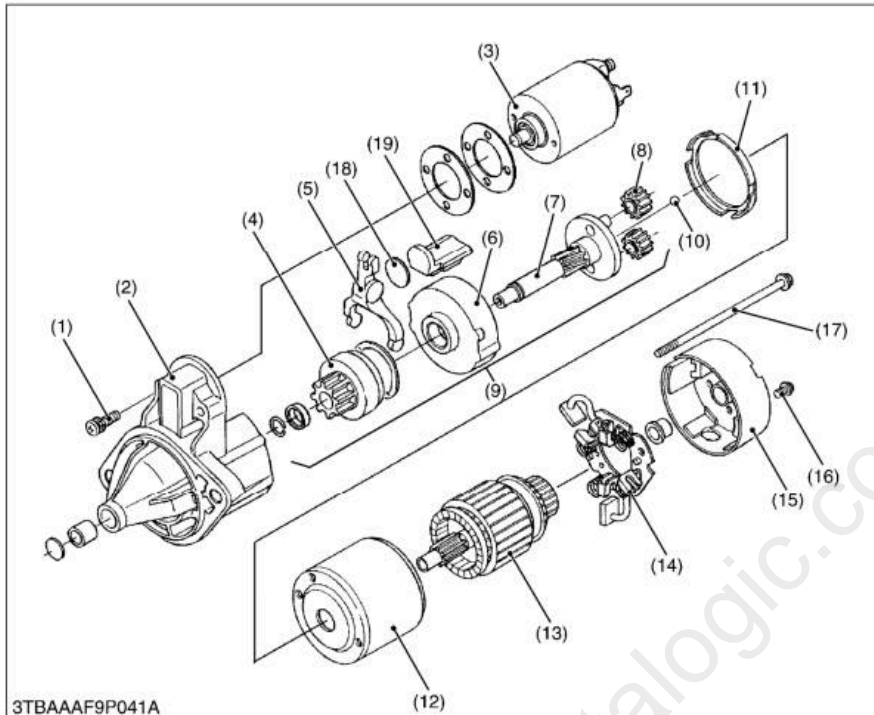

- (1) Screw
- (2) Front Bracket
- (3) Magnetic Switch
- (4) Overrunning Clutch
- (5) Drive Lever
- (6) Internal Gear
- (7) Shaft
- (8) Planetary Gear
- (9) Shaft Assembly
- (10) Ball
- (11) Gasket
- (12) Yoke
- (13) Armature
- (14) Brush Holder
- (15) Rear End Frame
- (16) Screw
- (17) Through Bolt
- (18) Plate
- (19) Gasket

3TBAAAF9P041A

1. Disconnect the connecting lead from the magnetic switch (3).
2. Remove the screw (1) and remove the magnetic switch (3).
3. Remove the screw (16) and through bolt (17), and separate the rear end frame (15).
4. Remove the brush holder (14).
5. Draw out the armature (13) and yoke (12).
6. Remove the gasket (11), gasket (19) and plate (18).
7. Draw out the shaft assembly (9) with the drive lever (5).

#### ■ NOTE

- Do not damage the brush and commutator.
- Do not miss the ball (10).

9Y1210623ELS0054US0

# Full Version Available

Kubota B3000-AUS Tractor Workshop Manual

This is a short preview. The complete manual contains all chapters, wiring diagrams, torque specifications and full service procedures.

**VIEW THE FULL MANUAL**

<https://machinecatalogic.com/kubota-b3000-aus-tractor-workshop-manual/>