

# WSM

---

WORKSHOP MANUAL  
**TRACTOR**  
**FRONT LOADER BACKHOE**

**B21 TL421 BT751**

---

**Kubota**

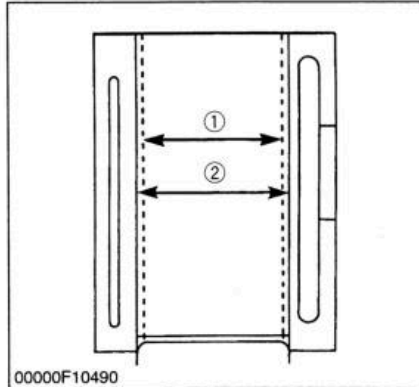
**Correcting Cylinder**

- When the cylinder is worn beyond the allowable limit, bore and hone it to the specified dimension.

Oversized cylinder I.D.	Factory spec.	76.500 to 76.519 mm 3.01181 to 3.01255 in.
	Allowable limit	76.669 mm 3.01846 in.

- Replace the piston and piston rings with oversize ones.

Oversize	Part Name	Code Number	Marking
0.5 mm 0.0197 in.	Piston 05	16251-21910	05 OS
	Piston ring 05 assembly	16271-21090	05 OS

**NOTE**

- When the oversize cylinder is worn beyond the allowable limit, replace the cylinder block with a new one.

(1) Cylinder I.D. (Before Correction)      (2) Oversized Cylinder I.D.

00000S10373

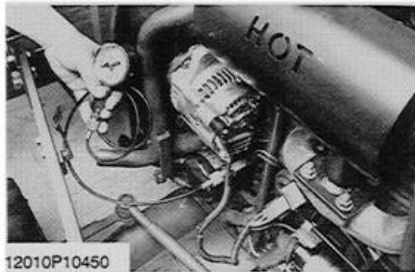
**[3] LUBRICATING SYSTEM CHECKING****Engine Oil Pressure**

- Remove the engine oil pressure switch, and set a oil pressure tester (Code No. 07916-32032).
- Start the engine. After warming up, measure the oil pressure of both idling and rated speeds.
- If the oil pressure is less than the allowable limit, check the following.
  - Engine oil insufficient
  - Oil pump defective
  - Oil strainer clogged
  - Oil filter cartridge clogged
  - Oil gallery clogged
  - Excessive oil clearance
  - Foreign matter in the relief valve

Engine oil pressure	At idle speed	Factory spec.	More than 49 kPa 0.5 kgf/cm <sup>2</sup> 7 psi
	At rated speed	Factory spec.	196 to 441 kPa 2.0 to 4.5 kgf/cm <sup>2</sup> 36 to 64 psi
		Allowable limit	147 kPa 1.5 kgf/cm <sup>2</sup> 27 psi

**(When reassembling)**

- After checking the engine oil pressure, tighten the engine oil pressure switch to the specified torque.

11900S10263

**(3) Separating Seat, Seat Stay, Step and HST Pedal**

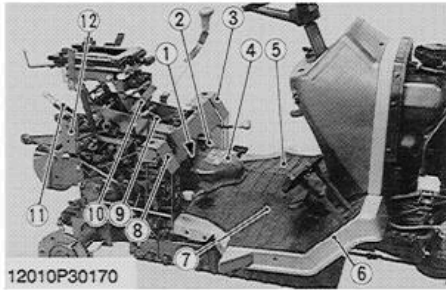

**Seat, Seat Stay and Steps**

1. Remove the seat.
2. Remove the lowering speed adjusting knob (2) and dipstick (1) then remove the seat under cover (4).
3. Remove the front wheel drive lever grip and PTO change lever grip, then remove their lever guide (3), (8).
4. Remove the hydraulic selector valve lever (9) and disconnect the hand accelerator rod (10) and return pipe (11) support, then remove the seat stay (12).
5. Remove the rubber mat (7).
6. Remove the clutch springs and remove the left hand side step (5).
7. Remove the brake springs and disconnect the parking brake rod then remove the right hand side step (6).

- |                                   |                                    |
|-----------------------------------|------------------------------------|
| (1) Dipstick                      | (7) Rubber Mat                     |
| (2) Lowering Speed Adjusting Knob | (8) Lever Guide RH                 |
| (3) Lever Guide LH                | (9) Hydraulic Selector Valve Lever |
| (4) Seat Under Cover              | (10) Hand Accelerator Rod          |
| (5) Step LH                       | (11) Return Pipe                   |
| (6) Step RH                       | (12) Seat Stay                     |

12010S30180

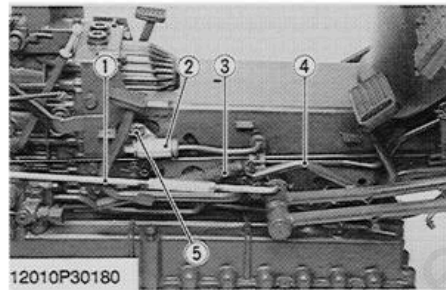

**HST Pedal**

1. Remove the brake rod RH (1).
2. Remove the damper (3).
3. Remove the speed control rod assembly (2).
4. Remove the external snap ring and draw out the HST pedal (4).
5. Remove the speed control rod screw (5) from the neutral holder.

**(When reassembling)**

- Apply lock tight to the speed control rod screw (5).

Tightening torque	Speed control rod screw	39.2 to 44.1 N·m 4.0 to 4.5 kgf·m 28.9 to 32.5 ft·lbs
-------------------	-------------------------	---

- |                                |                             |
|--------------------------------|-----------------------------|
| (1) Brake Rod RH               | (4) HST Pedal               |
| (2) Speed Control Rod Assembly | (5) Speed Control Rod Screw |
| (3) Damper                     |                             |

12010S30190

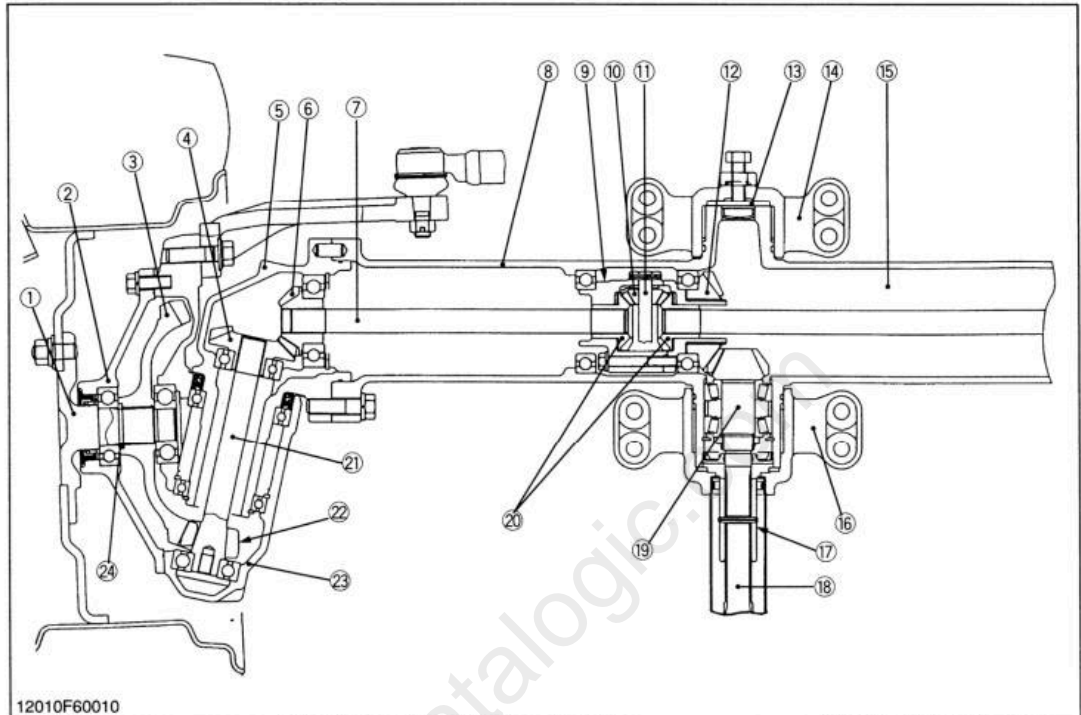
**[1] STRUCTURE**

12010F60010

- |                     |                                 |                                  |                                |
|---------------------|---------------------------------|----------------------------------|--------------------------------|
| (1) Axle            | (7) Differential Yoke Shaft, LH | (13) Collar                      | (19) Spiral Bevel Pinion Shaft |
| (2) Axle Flange     | (8) Front Axle Case             | (14) Front Axle Bracket, Front   | (20) Differential Side Gear    |
| (3) Bevel Gear      | (9) Differential Gear Assembly  | (15) Differential Yoke Shaft, RH | (21) Bevel Gear Shaft          |
| (4) Bevel Gear      | (10) Differential Pinion Gear   | (16) Front Axle Bracket, Rear    | (22) Bevel Gear                |
| (5) Bevel Gear Case | (11) Pinion Shaft               | (17) Coupling                    | (23) Front Gear Case           |
| (6) Bevel Gear      | (12) Spiral Bevel Gear          | (18) Propeller Shaft             | (24) Collar                    |

The front axle of the 4WD is constructed as shown above. Power is transmitted from the transmission through the propeller shaft (18) to the spiral bevel pinion shaft (19), then to the spiral bevel gear (12) and to the differential side gear (20).

The power through the differential side gear is transmitted to the differential yoke shaft (7), (15), and to the bevel gear shaft (21) through the bevel gears (4), (6) in the bevel gear case (5).

The revolution is greatly reduced by the bevel gears (22), (3), then the power is transmitted to the axle (1).

The differential system allows each wheel to rotate at a different speed to make turning easier.

12010M60010

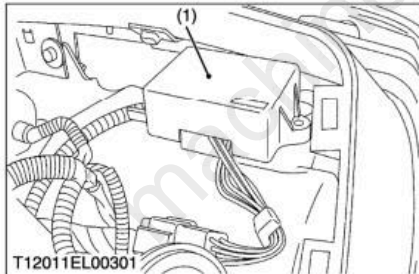
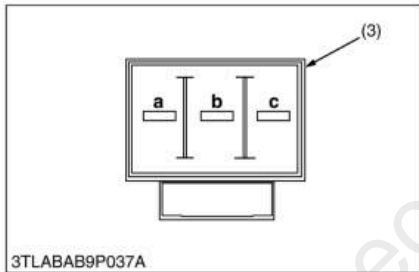
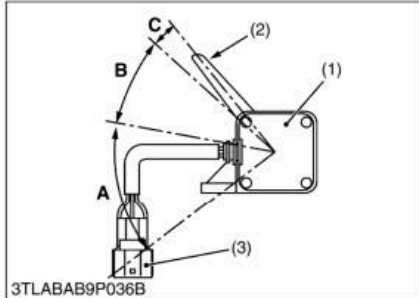
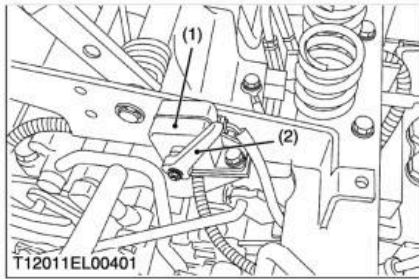

### Seat Switch

1. Release the seat lock.
2. Disconnect the seat turn switch connector (3).
3. Change the sensor bar (2) angle and measure the resistance between connector terminals, referring to the table below.
4. If the measurement does not between as table, switch is faulty.

Sensor bar angle	Measuring terminal	Resistance
Approx. 60 ° (Angle A)	a - c	0 Ω
	a - b, b - c	infinity
Approx. 25 ° (Angle B)	a - b, a - c, b - c	infinity
Approx. 5 ° (Angle C)	b - c	0 Ω
	a - b, a - c	infinity

- (1) Seat Switch  
(2) Sensor Bar

(3) Seat Switch Connector

W10184780

### Replacing Controller

1. If engine is not started, check all part regarding the starting system referring to "TROUBLESHOOTING".
2. If all part except the controller is not defective, replace the controller.

- (1) Controller

W1024727

# Full Version Available

Kubota BT751 Backhoe Workshop Manual

This is a short preview. The complete manual contains all chapters, wiring diagrams, torque specifications and full service procedures.

**VIEW THE FULL MANUAL**

<https://machinecatalogic.com/kubota-bt751-backhoe-workshop-manual/>