

WSM

WORKSHOP MANUAL
TRACTOR,
FRONT LOADER, BACKHOE

B26, TL500, BT820

Кубота

MECHANISM

CONTENTS

1. STRUCTURE	2-M1
2. FRONT CASE	2-M2
3. HYDROSTATIC TRANSMISSION	2-M3
[1] STRUCTURE	2-M3
[2] PUMP AND MOTOR	2-M5
[3] OIL FLOW AND VALVES	2-M6
[4] CONTROL LINKAGE	2-M14
4. RANGE GEAR SHIFT SECTION	2-M15
5. FRONT WHEEL DRIVE SECTION	2-M16
6. DIFFERENTIAL GEAR SYSTEM	2-M17
[1] DIFFERENTIAL FUNCTION	2-M17
[2] DIFFERENTIAL LOCK	2-M18
7. INDEPENDENT PTO	2-M19
[1] HYDRAULIC CIRCUIT	2-M19
[2] INDEPENDENT PTO CONTROL VALVE	2-M19
[3] INDEPENDENT PTO CLUTCH	2-M20
[4] INDEPENDENT PTO LEVER "ENGAGED"	2-M21
[5] INDEPENDENT PTO LEVER "DISENGAGED"	2-M22

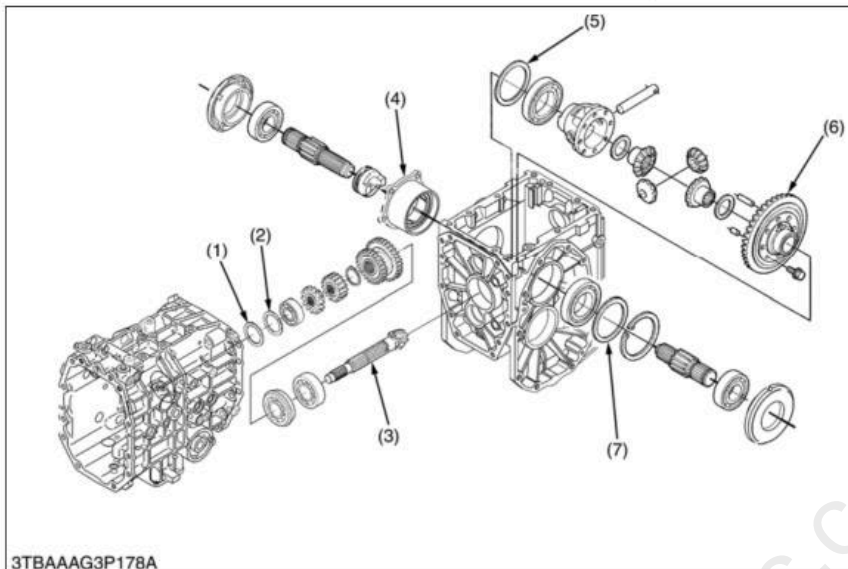
Backlash between Spiral Bevel Pinion and Spiral Bevel Gear

- (1) Shim
- (2) Shim
- (3) Spiral Bevel Pinion
- (4) Bearing Holder
- (5) Shim
- (6) Spiral Bevel Gear
- (7) Shim

W1029105

3TBAAAG3P178A

1. Set the dial indicator (lever type) with its finger on the end of spiral bevel pinion (3).
2. Move the spiral bevel pinion back and forth to each end and measure the side clearance.
3. If the side clearance exceeds the factory specifications, adjust with the shims (2) at front end of spiral bevel pinion.
4. Set the dial indicator (lever type) with its finger on the tooth surface of bevel gear.
5. Measure the backlash by fixing the spiral bevel pinion (2) and moving bevel gear (5) by hand.
6. If the backlash exceeds the factory specifications, adjust with the shims (2), (6) at bearing holder (7) and differential case.
7. Adjust the backlash properly by repeating the above procedure.

(When adjusting)

Movement of spiral bevel pinion shaft at shaft directions	Factory spec.	Approx. 0 mm 0 in.
Backlash between spiral bevel pinion and spiral bevel gear	Factory spec.	0.10 to 0.30 mm 0.0039 to 0.0012 in.

W1029368

(Reference)

- Thickness of shims (1):
0.2 mm (0.008 in.) 1.4 mm (0.055 in.)
- Thickness of shims (5), (7):
0.2 mm (0.008 in.) 0.5 mm (0.020 in.)

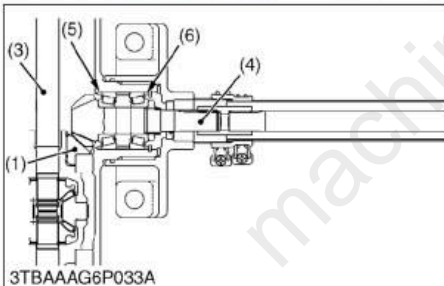
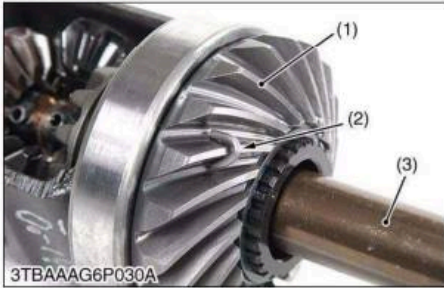

Backlash between Spiral Bevel Pinion Shaft and Spiral Bevel Gear

1. Place the fuse (2) on the gear tooth of the spiral bevel gear (1).
2. Install the spiral bevel gear (1) and the differential yoke shaft (3) into the front axle case.
3. Install the spiral bevel pinion shaft (4) to the front axle case. Install the internal cir-clip to the front axle case.
4. Turn the spiral bevel pinion shaft (4) holding the differential yoke shaft (3) by hand lightly.
5. Take out the fuse (2). And measure the fuse (2)
6. If the backlash is not within the factory specifications, change the adjusting collars (5) (6). For example change the adjusting collar (6) to 0.1 mm (0.004 in.) smaller size, and change the adjusting collar (5) to 0.1 mm (0.004 in.) larger size.
7. Adjust the backlash properly by repeating the above procedures.

Backlash between spiral bevel pinion shaft and spiral bevel gear	Factory spec.	0.10 to 0.30 mm 0.0040 to 0.011 in.
--	---------------	--

(Reference)

- Above factory specification should be measured on the tooth of spiral bevel pinion. When measuring the backlash on the spline of its shaft, factory specification will be 0.0571 to 0.1714 mm (0.00225 to 0.00675 in.).
- Thickness of adjusting collars (3) (4):

3.4 mm (0.134 in.)	4.1 mm (0.161 in.)
3.6 mm (0.142 in.)	4.2 mm (0.165 in.)
3.8 mm (0.150 in.)	4.4 mm (0.173 in.)
4.0 mm (0.157 in.)	4.6 mm (0.181 in.)

- | | |
|----------------------------------|-------------------------------------|
| (1) Spiral Bevel Gear (20T) | (4) Spiral Bevel Pinion Shaft (11T) |
| (2) Fuse | (5) Adjusting Collar |
| (3) Differential Yoke Shaft (RH) | (6) Adjusting Collar |

W1019697

SERVICING

CONTENTS

1. GENERAL	9-S1
[1] FRONT LOADER IDENTIFICATION	9-S1
[2] GENERAL PRECAUTION	9-S1
[3] LUBRICANTS	9-S2
[4] MAINTENANCE CHECK LIST	9-S2
[5] CHECK AND MAINTENANCE	9-S3
(1) Check Points of Each Use or Daily	9-S3
(2) Check Point of Every 10 Hours	9-S3
2. TROUBLESHOOTING	9-S4
3. SERVICING SPECIFICATIONS	9-S5
4. TIGHTENING TORQUES	9-S6
[1] GENERAL USE SCREWS, BOLTS AND NUTS	9-S6
[2] HYDRAULIC FITTINGS	9-S7
[3] TIGHTENING TORQUE FOR SPECIALLY SPECIFIED	9-S8
5. DISMOUNTING AND MOUNTING	9-S9
[1] DISMOUNTING FRONT LOADER ASSEMBLY	9-S9
[2] MOUNTING FRONT LOADER ASSEMBLY	9-S11
6. CHECKING AND ADJUSTING	9-S12
[1] RELIEF VALVE	9-S12
[2] SPILL GUARD	9-S13
[3] BUCKET, BOOM AND HYDRAULIC CYLINDERS	9-S15
(1) Disassembling and Assembling	9-S15
(2) Servicing	9-S19

Full Version Available

Kubota BT820 Backhoe Workshop Manual

This is a short preview. The complete manual contains all chapters, wiring diagrams, torque specifications and full service procedures.

VIEW THE FULL MANUAL

<https://machinecatalogic.com/kubota-bt820-backhoe-workshop-manual/>