

WSM

WORKSHOP MANUAL
**TRACTOR, ROTARY
MOWER**

**BX1880-AU, BX2380-AU,
BX2680-AU, RCK60B-23BX,
RCK54-23BX, RCK48-18BX,
RCK60D-26BX, RCK54D-26BX**

Kubota

2.5 Function of relief valve

The relief valve prevents the damage of the lubricating system due to high oil pressure.

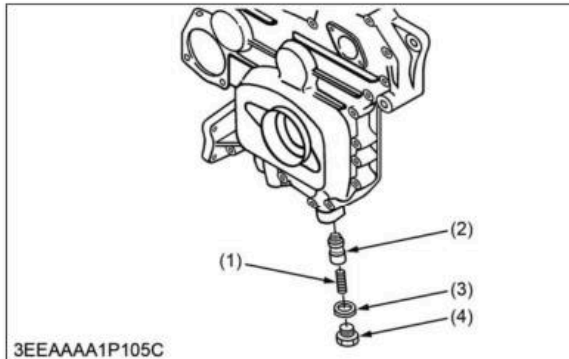

- (1) Spring
- (2) Poppet
- (3) Gasket
- (4) Plug

The valve is closed when the spring tension is greater than the oil pressure at the inlet. The spring tension holds poppet (2) securely in position. The valve opens when the oil pressure at the inlet exceeds that of the spring (1). This pushes the poppet off the inlet hole and oil flows through the valve.

2.6 Function of oil pressure switch

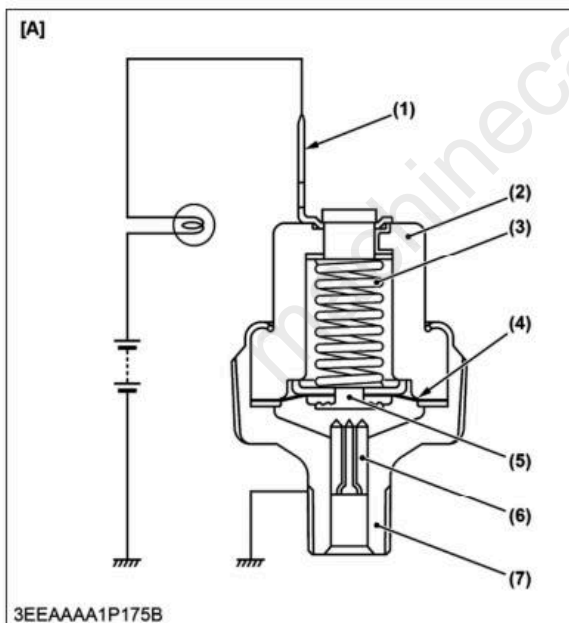

3EEAAAA1P175B

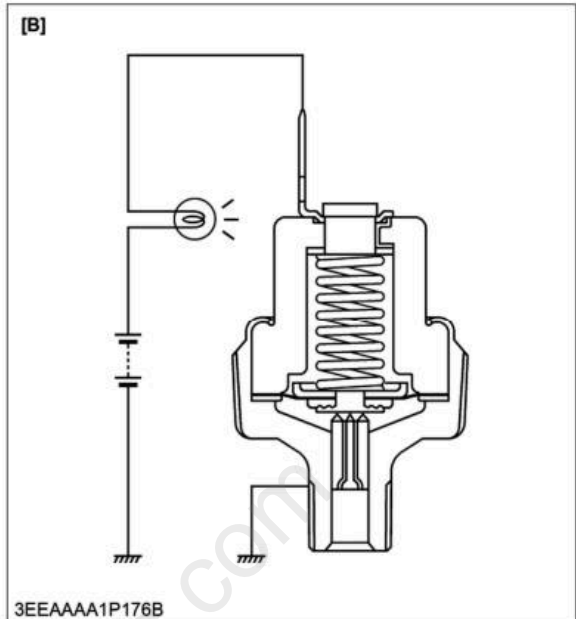

3EEAAAA1P176B

- (1) Terminal
- (2) Insulator
- (3) Spring
- (4) Diaphragm
- (5) Contact rivet
- (6) Contact
- (7) Oil switch body
- [A] At proper oil pressure
- [B] At lower oil pressure

The oil pressure switch is mounted on the cylinder block and is led to the lubricating oil passage. When the oil pressure falls below the specified value, the oil pressure-warning lamp lights.

[A] At proper oil pressure

When the engine is started and as the proper oil pressure builds, the diaphragm (4) is pushed up. This separates the contact rivet (5) and breaks the circuit, causing the lamp to go out.

[B] At lower oil pressure, 49 kPa (0.50 kgf/cm², 7.1 psi) or less

If the oil pressure drops, the resulting deflection of the diaphragm (4) will close the contact rivet (5) and again complete the circuit. The lighted lamp warns that the pressure of the lubricating system has dropped below the pressure setting.

Undersize	0.20 mm 0.0079 in.	0.40 mm 0.016 in.
Dimension D	51.721 to 51.740 mm dia. 2.0362 to 2.0370 in. dia.	51.521 to 51.540 mm dia. 2.0284 to 2.0291 in. dia.
The crankshaft journal must be fine-finished to higher than Max. = 0.8S		

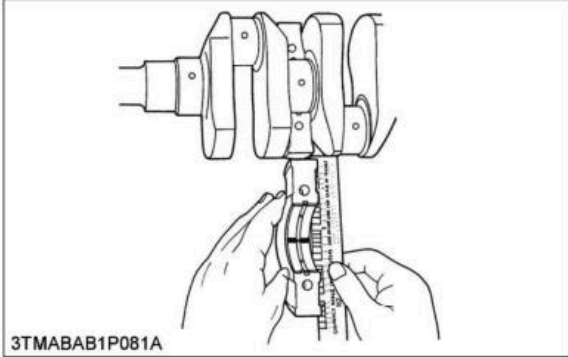

6.5 Cylinder

6.5.1 Checking cylinder wear

Tools required

- Cylinder gauge

1. Measure the I.D. of the cylinder at the six positions (see figure) with a cylinder gauge to find the maximum and minimum I.D.'s.

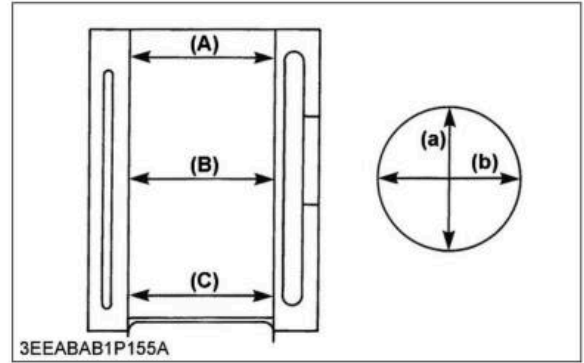
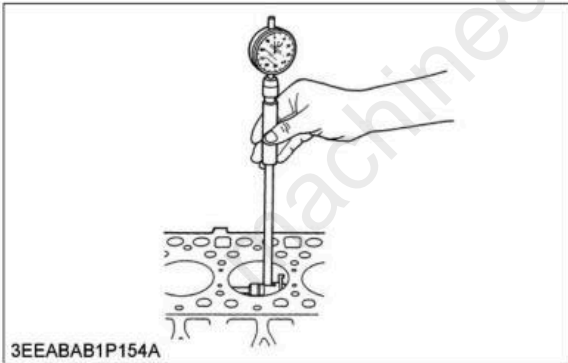

- (A) Top
(B) Middle
(C) Bottom (Skirt)
- (a) Right-angled to piston pin
(b) Piston pin direction

2. Get the difference (maximum wear) between the maximum and the minimum I.D.'s.
3. If the wear exceeds the service limit, bore and hone to the oversize dimension.

BX1880

Cylinder liner I.D.	Service specification	67.000 to 67.019 mm 2.6378 to 2.6385 in.
	Service limit	67.150 mm 2.6437 in.

BX2380

Cylinder liner I.D.	Service specification	72.000 to 72.019 mm 2.8347 to 2.8353 in.
	Service limit	72.150 mm 2.8406 in.

BX2680

Cylinder liner I.D.	Service specification	76.000 to 76.019 mm 2.9922 to 2.9928 in.
	Service limit	76.15 mm 2.998 in.

4. Visually check the cylinder wall for scratches. If deep scratches are found, the cylinder should be bored.

— RELATED PAGE —

[6.5.2 Correcting cylinder \(Oversize\) on page 3-78](#)

5.2 Hydrostatic transmission

5.2.1 Removing levers and mower lift arm

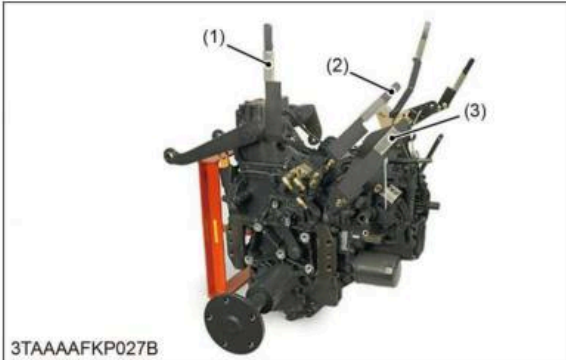

- (1) Range gear shift lever (3) Front wheel drive lever
(2) Hydraulic control lever

1. Tap out the spring pin from the range gear shift lever (1) and front wheel drive lever (3), then remove the both levers.
2. Remove the hydraulic control lever (2).
3. Remove the PTO select lever (4) and PTO clutch control lever (5).

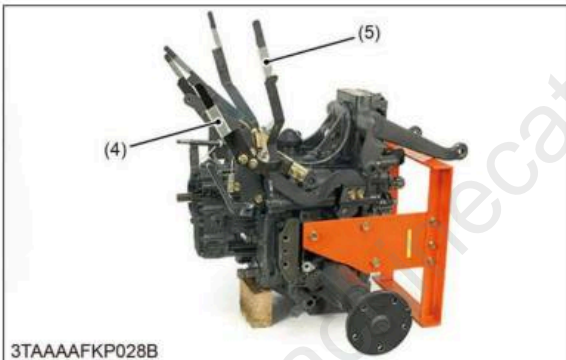

- (4) PTO select lever (5) PTO clutch control lever

(When reassembling)

- Apply grease to inside of the front coupling and rear mounting.

Tightening torque	Hydraulic control lever mounting bolt and nut	18 to 20 N·m 1.8 to 2.1 kgf·m 13 to 15 lbf·ft
-------------------	---	---

5.2.2 Removing PTO clutch valve

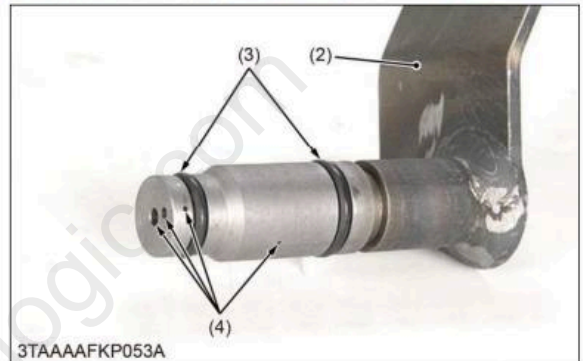

- (1) Stopper (3) O-ring
(2) PTO clutch valve (4) Oil passage

1. Remove the stopper (1).
2. Draw out the PTO clutch valve (2) from the transaxle assembly.

(When reassembling)

1. Clean the oil passages (4).
2. Apply the transmission fluid to the O-rings (3).

5.2.3 Removing center section

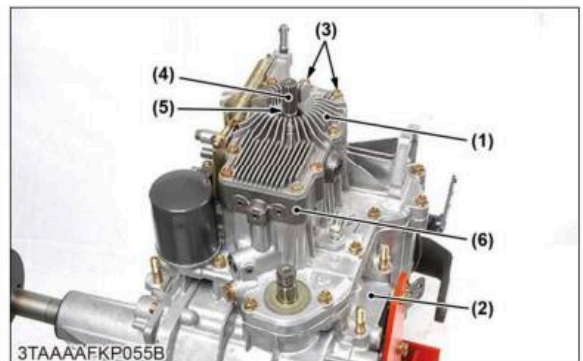

- (1) Oil cooler cover (4) Clutch pump shaft
(2) Transaxle assembly (5) Bearing
(3) Bolt/Nut (6) Center section

2. Electrical connector chart

 3RD_FLUC AMP_EI_11832J AL_BATTERY(+) YAZAKI_7166-3105 ALT_B RING_TERMINAL_LA_M8 ALT_B SUMITOMO_TS090 6189-0442 EARTH_TERMINAL_BA_M8 SATT(+) YAZAKI_SUL 7123-115-30 BODY(EARTH)(FRAME) RING_TERMINAL_LA_M8 BODY(EARTH)(STARTER) RING_TERMINAL_LA_M8 COMB1_SW SUMITOMO_MT096 6244-5121 DC_OUTLET YAZAKI_POSITIVE_LOCK 7123-8222	FLASHER UNIT SUMITOMO_MT090 6242-5881 FUEL_PUMP SUMITOMO_250 6070-2481 *1 010 7 011 FUEL_SSR(+) AMP_POSITIVE_LOCK(MK /) 154719-1 FUEL_SSR(-) AMP_POSITIVE_LOCK(MK /) 154719-0 FUEL_SSR(+) FLUSE_BOX PKG_E-433 3,010 7 110 GLOW_PLUG RING_TERMINAL_LE_M4 GRO(U)U RING_TERMINAL_LA_M8 *1 053 7 081 ON(D)O RING_TERMINAL_LA_M8 *1 053 7 071 HAZARD_LAMP(L-) BULLET_TERMINAL_RECEPTACLE CB	HAZARD_LAMP(L-) BULLET_TERMINAL_PLUG CA *1 053 7 056 HAZARD_LAMP(R-) BULLET_TERMINAL_RECEPTACLE CB HAZARD_LAMP(R-) BULLET_TERMINAL_PLUG CA *1 053 7 056 HEAD_LIGHT(L) DELPHI_AMIHFD320 1212819 HEAD_LIGHT(R) DELPHI_AMIHFD320 1212819 MAIN_SW SUMITOMO_DL 220 61055041 NEUTRAL_SW MOLEX_MX150 33472-0801 OIL_PRESS_SW YAZAKI_Z50 7116-2020 RANEL JAE_M034 MACH0081F PTO_SW MOLEX_MX150 33472-0801	REAR_PTO_SW MOLEX_MX150 33472-0801 FUEL(COOL) BOSCH 3334-485-007 RLY(WALIGHT) BOSCH 3334-485-007 RLY(LAMP) BOSCH 3334-485-007 RLY(STARTER) BOSCH 3334-485-007 SAFETY_SW(SEAT) SUMITOMO_MT090 6189-2121 SAFETY_SW(SEAT_TURN_SWER) DELTA 90209 SRP SOLENOID PKG_E-4321 YAZAKI_CNA connector diagram YAZAKI_CNA 7123-2115	STARTER_S YAZAKI_CNA 7123-2115 TAL_LIGHT(L-) BULLET_TERMINAL_RECEPTACLE CB TAL_LIGHT(L-) BULLET_TERMINAL_RECEPTACLE CB TAL_LIGHT(L-) SUMITOMO_LPT090 6187-2171 TO_OUTLET_H SUMITOMO_MT090 6182-2181 TO_MAIN_L(SEAT) AMP_EI_11832J TO_SEAT_H AMP_EI_11832J WATER_TEMP_SSR WORKLIGHT_RLY BOSCH 3334-485-007 WORK_LIGHT(L) SUMITOMO_Z50 6070-2481 WORK_LIGHT(R) SUMITOMO_Z50 6070-2481	TO MAIN-1 BULLET_TERMINAL_RECEPTACLE CB TO_WORK_LIGHT(+) BULLET_TERMINAL_RECEPTACLE CB TO MAIN (COUTLET) SUMITOMO_LPT090 6187-2171 TO_OUTLET_H SUMITOMO_MT090 6182-2181 TO_MAIN_L(SEAT) AMP_EI_11832J TO_SEAT_H AMP_EI_11832J WATER_TEMP_SSR WORKLIGHT_RLY BOSCH 3334-485-007 WORK_LIGHT(L) SUMITOMO_Z50 6070-2481 WORK_LIGHT(R) SUMITOMO_Z50 6070-2481
---	--	--	--	---	---

2LEQP00081A01

Full Version Available

Kubota BX1880-AU Tractor Workshop Manual

This is a short preview. The complete manual contains all chapters, wiring diagrams, torque specifications and full service procedures.

VIEW THE FULL MANUAL

<https://machinecatalogic.com/kubota-bx1880-au-tractor-workshop-manual/>