

WSM

WORKSHOP MANUAL
TRACTOR, ROTARY MOWER,
FRONT LOADER

**BX1850, BX2350, RCK48-18BX,
RCK54-23BX, RCK60B-23BX,
RCK48P-18BX, RCK54P-23BX,
LA203, LA243**

Kubota

		0.0059 in.
Backlash between idle gear and injection pump gear	Factory spec.	0.046 to 0.124 mm 0.00181 to 0.00488 in.
	Allowable limit	0.15 mm 0.0059 in.
Backlash between oil pump drive gear and crank gear	Factory spec.	0.041 to 0.123 mm 0.00161 to 0.00484 in.
	Allowable limit	0.15 mm 0.0059 in.

W11264830

1-S48

KISC issued 08, 2019 A

BX1850, BX2350, RCK48(P)-18BX, RCK54(P)-23BX, RCK60B-23BX, LA203, LA243, WSM

ENGINE

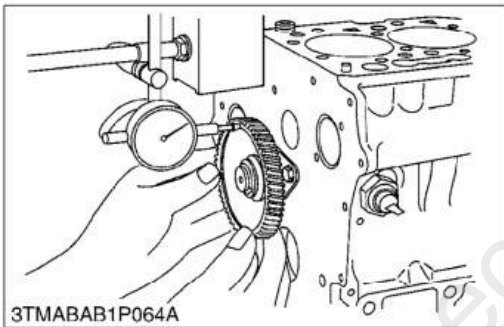

Idle Gear Side Clearance

1. Set a dial indicator with its tip on the idle gear.
2. Measure the side clearance by moving the idle gear to the front and rear.
3. If the measurement exceeds the allowable limit, replace the idle gear collar.

Idle gear side clearance	Factory spec.	0.20 to 0.51 mm 0.0079 to 0.0201 in.
	Allowable limit	0.80 mm 0.0315 in.

W11286770

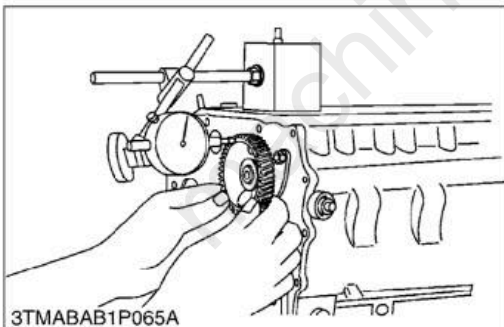

Camshaft Side Clearance

1. Set a dial indicator with its tip on the camshaft.
2. Measure the side clearance by moving the cam gear to the front and rear.
3. If the measurement exceeds the allowable limit, replace the camshaft stopper.

Camshaft side clearance	Factory spec.	0.15 to 0.31 mm 0.0059 to 0.0122 in.
	Allowable limit	0.50 mm 0.0197 in.

W11299720

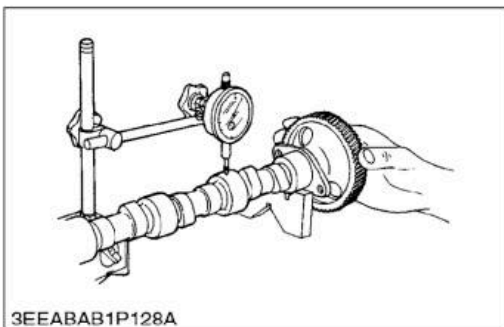

Camshaft Alignment

1. Support the camshaft with V blocks on the surface plate at both end journals.
2. Set a dial indicator with its tip on the intermediate journal.
3. Measure the camshaft alignment.
4. If the measurement exceeds the allowable limit, replace the camshaft.

Camshaft alignment	Allowable limit	0.01 mm 0.0004 in.
--------------------	-----------------	-----------------------

W11312720

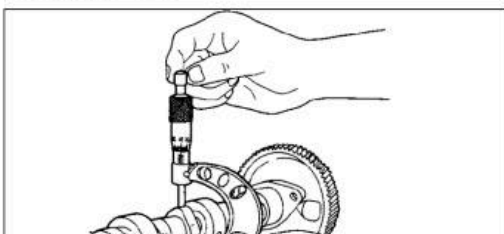

Cam Height

1. Measure the height of the cam at its highest point with an outside micrometer.
2. If the measurement is less than the allowable limit, replace the camshaft.

Cam height of intake	Factory spec.	26.88 mm 1.0583 in.
----------------------	---------------	------------------------

3TAAAFKP052A

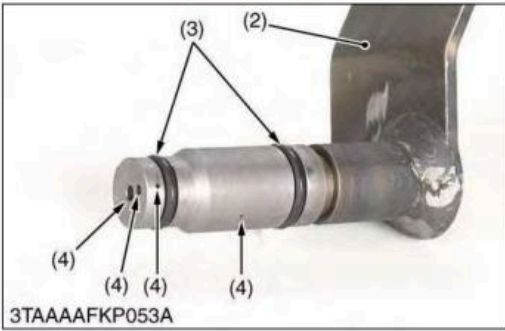

3TAAAFKP053A

2-S24

KISC issued 08, 2019 A

BX1850, BX2350, RCK48(P)-18BX, RCK54(P)-23BX, RCK60B-23BX, LA203, LA243, WSM

TRANSAXLE



3TAAAFKP054A

Oil Cooler Cover

1. Remove the HST front cover.
2. Remove the HST front cover (1) not to damage the oil seal (5).
3. Remove the center section (6).

(When reassembling)

1. Do not damage the oil seal (5).
2. Tighten the HST mounting bolts and the nut to the factory specifications.

Tightening torque	Oil cooler cover mounting bolt (M8)	18.0 to 21.0 N·m 1.8 to 2.1 kgf·m 13.3 to 15.5 ft-lbs
	Oil cooler cover mounting nut (M8)	18.0 to 21.0 N·m 1.8 to 2.1 kgf·m 13.3 to 15.5 ft-lbs

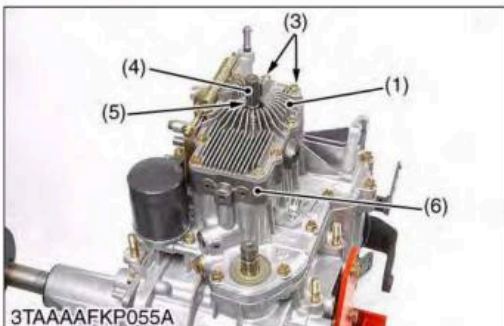

3TAAAFKP055A

- (1) HST Front Cover
- (2) Transaxle Assembly
- (3) Bolt
- (4) Internal Cir-clip
- (5) Oil Seal
- (6) Center Section

W1086612

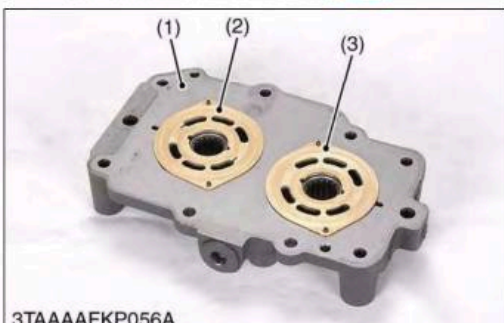

3TAAAFKP056A

Center Section and Valve Plates

1. Remove the valve plates (2) (4).

(When reassembling)

1. Check the direction of the groove (4).
2. Install the valve plates (2) (3) to the anchor pins (5) securely.
3. Install the groove (6) of the valve plate (pump plate) to the engine side.

- (1) Center Section
- (2) Valve Plate (Pump Shaft)
- (3) Valve Plate (Motor Shaft)
- (4) Groove
- (5) Anchor Pin
- (6) Groove

W1086612

BX1850, BX2350, RCK48(P)-18BX, RCK54(P)-23BX, RCK60B-23BX, LA203, LA243, WSM

FRONT AXLE

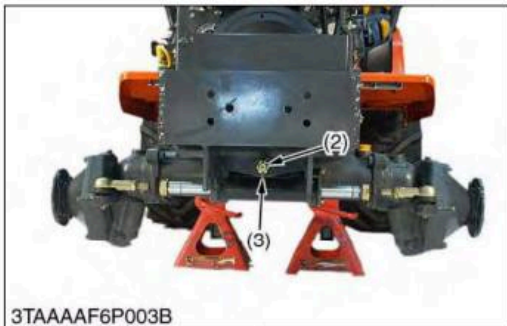
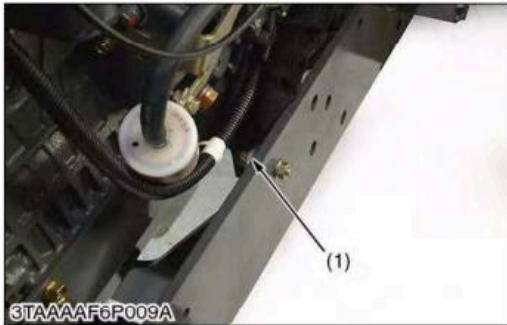
**Front Axle Assembly [BX2350]**

1. Remove the power steering hose clamp (1).
2. Place the garage jack under the front axle.
3. Remove the cotter pin (1).
4. Remove the slotted nut (2) of center pin and separate the front axle from the frame.
5. Disconnect the power steering cylinder hoses (4).

(When reassembling)

- After mounting the front axle assembly to the frame, be sure to adjust the front axle rocking force. (See page 3-S5.)
- Installing the cotter pin, be sure to split the cotter pin like an anchor

Tightening torque	Power steering cylinder hose	23.6 to 27.4 N·m 2.4 to 2.8 kgf·m 17.4 to 20.2 ft·lbs
-------------------	------------------------------	---

- (1) Hose Clamp
(2) Cotter Pin

- (3) Slotted Nut (Adjusting Nut for Front Axle Rocking Force)
(4) Power Steering Hose

W1023380

BX1850, BX2350, RCK48(P)-18BX, RCK54(P)-23BX, RCK60B-23BX, LA203, LA243, WSM

ELECTRICAL SYSTEM

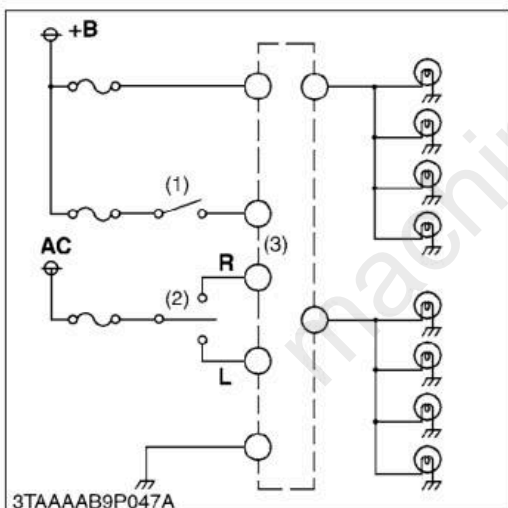
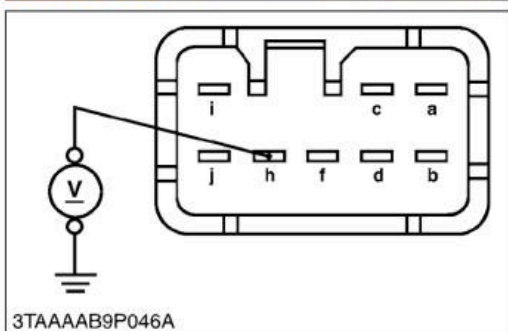

Flasher Unit

1. Remove the under panel.
2. Disconnect the coupler (2) from flasher unit.
3. Measure the voltage with a voltmeter across the terminal **h** and terminal **c** or chassis.
4. If the voltage differs from the battery voltage, the wiring harness is faulty.

Voltage	Terminal h – Terminal c or Chassis	Approx. battery voltage
---------	---	-------------------------

(1) Flasher Unit

(2) Coupler

W1055033

Flasher Unit Actuation Test

1. Set the hazard switch to the **ON** position, and make sure the hazard light gives 60 to 85 flashes for a minute.
2. With the main switch and the hazard switch at the **ACC** and **ON** positions, respectively, move the turn signal light switch to the left. Make sure that the right-hand light stays on and the left-hand light gives flashes earlier (by about 20 flashes) than when the hazard lamp is activated. Then move the turn signal light switch to the right and make sure the corresponding actions take place.
3. Now set the main switch to the **ACC** position and move the blinker switch alone. Make sure the same actions as above result.
4. If both the hazard switch and the turn signal light switch function but the above actions do not take place, replace the flasher unit with new one.

(1) Hazard Light Switch

(3) Flasher Unit

(2) Turn Signal Light Switch

W36974125

Full Version Available

Kubota BX2350 Tractor Workshop Manual

This is a short preview. The complete manual contains all chapters, wiring diagrams, torque specifications and full service procedures.

VIEW THE FULL MANUAL

<https://machinecatalogic.com/kubota-bx2350-tractor-workshop-manual/>