

WSM

WORKSHOP MANUAL

G1700, G1800, G1900, G2000

Кубота

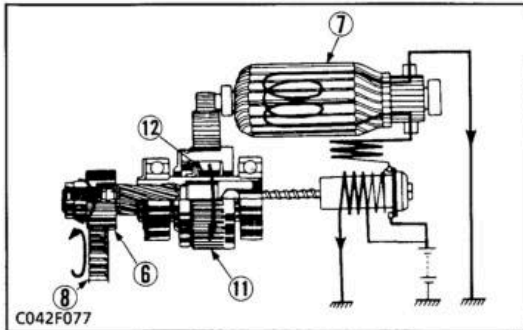

■ When the Engine is Running

When the engine runs so fast that the ring gear (8) starts to turn the pinion gear (6), the roller clutch (11), (12) are actuated to prevent excessive high-speed revolutions of the armature (7).

- | | |
|-----------------|------------------|
| (6) Pinion Gear | (11) Clutch Gear |
| (7) Armature | (12) Roller |
| (8) Ring Gear | |

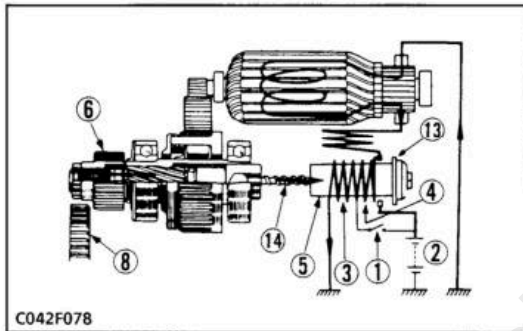

■ When the Main Switch is Released

When the main switch (1) released, the main switch returns from the **START** to the **ON** position and opens the starter circuit. Then, current flows from the battery (2) to the pull-in coil (4) and holding coil (3) through the contact plate (13). Since the magnetic forces of the pull-in coil and holding coil become partially opposed and cancel one another, the plunger (5) is restored by the tension of the return spring (14).

This opens the contacts on the contact plate and separates the pinion gear (6) from the ring gear (8), so that the pinion gear stops rotating.

- | | |
|------------------|--------------------|
| (1) Main Switch | (6) Pinion Gear |
| (2) Battery | (8) Ring Gear |
| (3) Holding Coil | (13) Contact Plate |
| (4) Pull-in Coil | (14) Return Spring |
| (5) Plunger | |

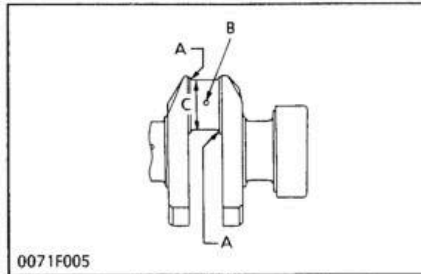
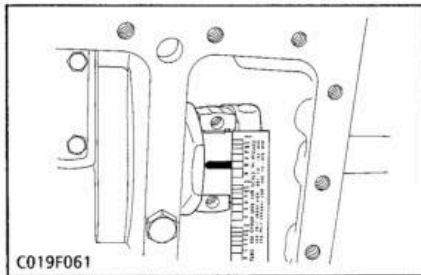

Oil Clearance between Crank Pin and Crank Pin Bearing

1. Clean the crank pin and crank pin bearing.
2. Put a strip of press gauge (Code No. 07909-30241) on the center of the crank pin.

IMPORTANT

- Never insert the press gauge into the crank pin oil hole.
3. Install the connecting rod cap and tighten the connecting rod screws to the specified torque (26.5 to 30.4 N·m, 2.7 to 3.1 kgf·m, 19.5 to 22.4 ft·lbs), and remove the cap again.

NOTE

- Be sure not to move the crankshaft while the connecting rod screws are tightened.
4. Measure the amount of the flattening with the scale, and get the oil clearance.
 5. If the oil clearance exceeds the allowable limit, replace the crank pin bearing.
 6. If the same size bearing is useless because of the crank pin wear, replace it with an undersize one referring to the table and figure.

Oil clearance between crank pin and crank pin bearing	Factory spec	0.019 to 0.081 mm 0.00075 to 0.00319 in.
	Allowable limit	0.15 mm 0.0059 in.

Crank pin O.D.	Factory spec.	33.959 to 33.975 mm 1.33697 to 1.33760 in.
Crank pin bearing I.D.	Factory spec.	33.994 to 34.040 mm 1.33835 to 1.34016 in.

(Reference)

- Undersize crank pin bearing

Undersize	Bearing	Code Number	Marking
0.2 mm 0.008 in.	Crank pin bearing 02	15861-22971	020 US
0.4 mm 0.016 in.	Crank pin bearing 04	15861-22981	040 US

- Undersize dimensions of crank pin

Undersize Dimension	0.2 mm 0.008 in.	0.4 mm 0.016 in.
A	2.3 to 2.7 mm radius 0.091 to 0.106 in. radius	2.3 to 2.7 mm radius 0.091 to 0.106 in. radius
B	4 mm dia. 0.16 in. dia.	4 mm dia. 0.16 in. dia.
C	33.759 to 33.775 mm 1.32910 to 1.32973 in.	33.559 to 33.575 mm 1.32122 to 1.32185 in.
The crank pin must be fine-finished to higher than $\nabla\nabla\nabla\nabla$ (0.45).		

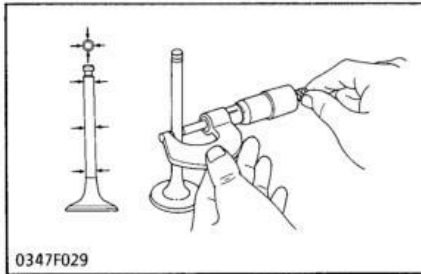

0347F029

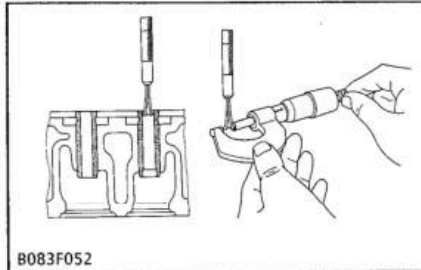

B083F052

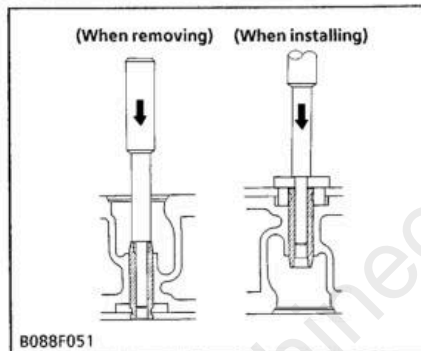

B088F051

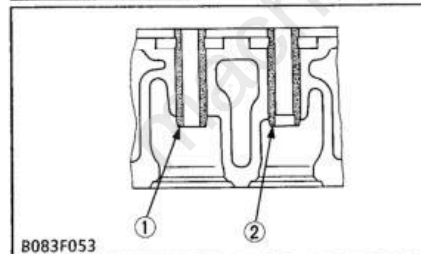

B083F053

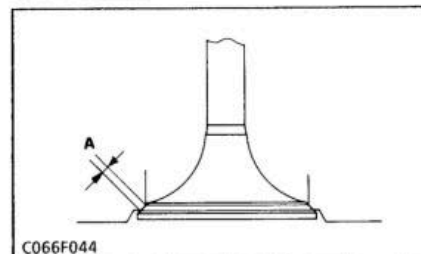

C066F044

Clearance between Valve Stem and Valve Guide

1. Remove carbon from the valve guide section.
2. Measure the valve stem O.D. with an outside micrometer.
3. Measure the valve guide I.D. with a small hole gauge, and calculate the clearance.
4. If the clearance exceeds the allowable limit, replace the valve guide or valve.

Clearance between valve stem and valve guide	Factory spec.	0.030 to 0.057 mm 0.00118 to 0.00224 in.
	Allowable limit	0.1 mm 0.0039 in.

Valve stem O.D.	Factory spec.	5.968 to 5.980 mm 0.23496 to 0.23543 in.
Valve guide I.D.	Factory spec	6.010 to 6.025 mm 0.23661 to 0.23720 in.

Replacing Valve Guide

(When removing)

1. Using a valve guide replacing tool (see page S.G-20), press out the used valve guide.

(When installing)

1. Clean a new valve guide, and apply engine oil to it.
2. Using a valve guide replacing tool, press in a new valve guide until it is flush with the cylinder head as shown in the figure.
3. Ream precisely the I.D. of the valve guide to the specified dimension.

Valve guide I.D. (Intake and exhaust)	Factory spec	6.010 to 6.025 mm 0.23661 to 0.23721 in.
--	--------------	---

■ IMPORTANT

- Do not hit the valve guide with a hammer, etc. during replacement.

(1) Intake Valve Guide

(2) Exhaust Valve Guide

Width of Contact between Valve and Valve Seat

1. Check the contact between the valve face and valve seat.
2. If the contact is uneven or the width of contact (A) is excessively large, correct the valve and valve seat referring to "Correcting Valve and Valve Seat".

Valve seat width	Factory spec	2.12 mm 0.0835 in.
------------------	--------------	-----------------------

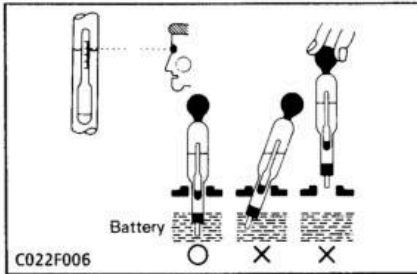

C022F006

Specific Gravity	State of Charge
1.260 Sp. Gr.	100% Charged
1.230 Sp. Gr.	75% Charged
1.200 Sp. Gr.	50% Charged
1.170 Sp. Gr.	25% Charged
1.140 Sp. Gr.	Very Little Useful Capacity
1.110 Sp. Gr.	Discharged

At an electrolyte temperature of 20°C (68°F)

NOTE

- Hold the hydrometer tube vertical without removing it from the electrolyte.
- Allow the float to move freely and hold the hydrometer at eye level.
- The hydrometer reading must be taken at the highest electrolyte level.

[2] STARTING SYSTEM**CHECKING****(1) Main Switch**

B083P120

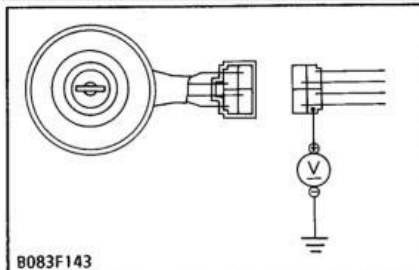

B083F143

Gravity of Battery Electrolyte**CAUTION**

- Never remove the battery cap while the engine is running.
- Keep electrolyte away from eyes, hands and clothes. If you are spattered with it, flush with water immediately, and see your doctor.

1. Check the specific gravity of the electrolyte in each cell with a hydrometer.
2. When the electrolyte temperature differs from that at which the hydrometer was calibrated, correct the specific gravity reading following the formula mentioned in (Reference) below.
3. If the specific gravity is less than 1.215 (after it is corrected for temperature), charge or replace the battery.
4. If the specific gravity differs between any two cells by more than 0.05, replace the battery.

(Reference)

- Specific gravity varies slightly with temperature. To be exact, the specific gravity decreases by 0.0007 (0.0004) with an increase of 1 °C (34 °F) in temperature, and increases by 0.0007 (0.0004) with a decrease of 1 °C (34 °F). Therefore, using 20 °C (68 °F) as a reference, the specific gravity reading must be corrected by the following formula:

$$\text{Specific gravity at } 20\text{ }^{\circ}\text{C} = \text{Measured value} + 0.0007 \times (\text{Electrolyte temperature} - 20\text{ }^{\circ}\text{C})$$

$$\text{Specific gravity at } 68\text{ }^{\circ}\text{F} = \text{Measured value} + 0.0004 \times (\text{Electrolyte temperature} - 68\text{ }^{\circ}\text{F})$$

Terminal Voltage

1. Disconnect the 4P connector from the main switch.
2. Measure the voltage with a voltmeter across the terminal (1) and chassis.
3. If the voltage differs from the battery voltage, the wiring harness is faulty.

Voltage (Terminal - Chassis)	Factory spec.	Approx. battery voltage

Full Version Available

Kubota G1800 Lawn Tractor Workshop Manual

This is a short preview. The complete manual contains all chapters, wiring diagrams, torque specifications and full service procedures.

VIEW THE FULL MANUAL

<https://machinecatalogic.com/kubota-g1800-lawn-tractor-workshop-manual/>