

# WSM

---

WORKSHOP MANUAL

G21LD, G21HD

---

**Kubota**

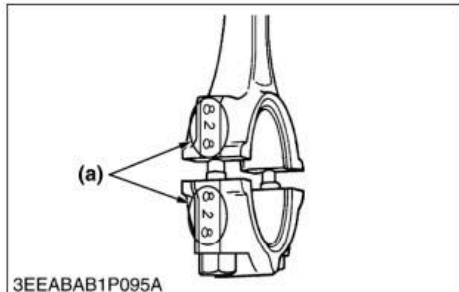
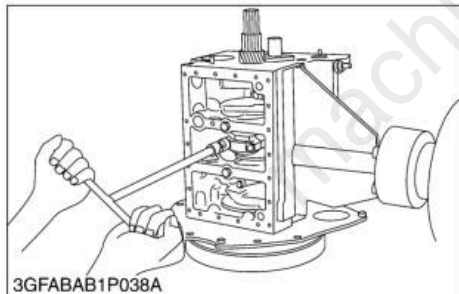
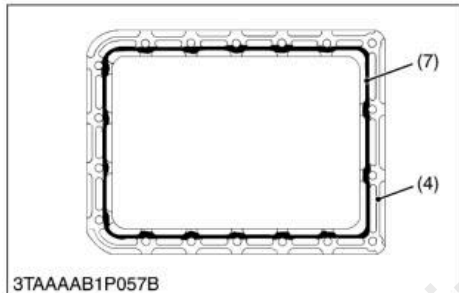
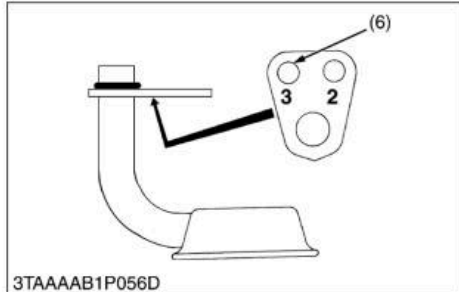
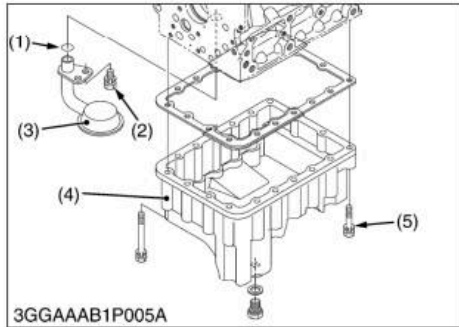
**(C) Connecting Rod and Piston****Oil Pan and Oil Strainer**

1. Remove the oil pan (4).
2. Remove the oil strainer (3).

**(When reassembling)**

- Install the oil strainer, using care not to damage the O-ring (1).
- Using the hole (6) numbered "3", install the oil strainer by mounting screw.
- Apply liquid gasket (Three Bond 1270D or 1270C) to the oil pan as shown in the figure.

**■ IMPORTANT**

- **Scrape off the old adhesive completely. Wipe the sealing surface clean using waste cloth soaked with gasoline. Now apply new adhesive 3 to 5 mm (0.12 to 0.20 in.) thick all over the contact surface. Apply the adhesive also on the center of the flange as well as on the inner wall of each bolt hole.**
- **Cut the nozzle of the "fluid sealant" container at its second notch. Apply "fluid sealant" about 5 mm (0.20 in.) thick. Within 20 minutes after the application of fluid sealant, reassemble the components. Wait then for about 30 minutes, and pour oil in the crankcase.**

- |                  |                             |
|------------------|-----------------------------|
| (1) O-ring       | (5) Oil Pan Mounting Screws |
| (2) Screw        | (6) Hole                    |
| (3) Oil Strainer | (7) Fluid Sealant           |
| (4) Oil Pan      |                             |

W10265670

**Connecting Rod Cap**

1. Remove the connecting rod screws from connecting rod cap.
2. Remove the connecting rod caps.

**(When reassembling)**

- Align the marks (a) with each other. (Face the marks toward the injection pump.)
- Apply engine oil to the connecting rod screws and lightly screw it in by hand, then tighten it to the specified torque. If the connecting rod screw won't be screwed in smoothly, clean the threads. If the connecting rod screw is still hard to screw in, replace it.
- Do not change the combination of crankpin bearing and connecting rod.

Tightening torque	Connecting rod screw	26.5 to 30.4 N·m 2.7 to 3.1 kgf·m 19.5 to 22.4 ft·lbs
-------------------	----------------------	---

(a) Mark

W10275480

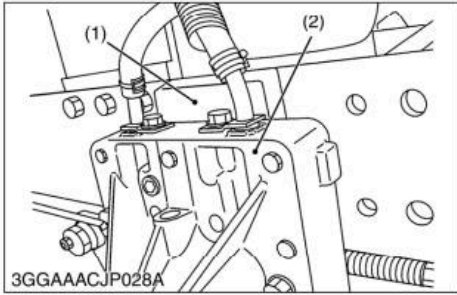
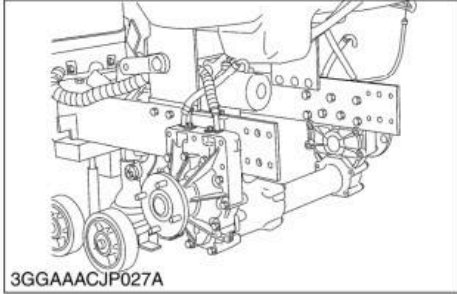

### Separating Transmission

1. Remove the universal joint mounting screws.
2. Disconnect the universal joint.
3. Remove the rear axle case mounting screws.
4. Separating the transmission from the frame.

### (When reassembling)

- Apply grease to the splines of universal joint.
- Fit the rear axle case onto the frame with the rear axle case top in tight contact all over the plate.

Tightening torque	Universal joint mounting screw	23.5 to 27.4 N·m 2.4 to 2.8 kgf·m 17.4 to 20.3 ft-lbs
	Rear axle case mounting screw (M12 7T Aluminum)	62.7 to 72.5 N·m 6.4 to 7.4 kgf·m 46.3 to 53.5 ft-lbs
	Rear axle case mounting screw (M10 7T Aluminum)	39.2 to 44.1 N·m 4.0 to 4.5 kgf·m 28.9 to 32.5 ft-lbs
	Rear axle case mounting screw (M12 7T)	77.4 to 90.2 N·m 7.9 to 9.2 kgf·m 57.1 to 66.5 ft-lbs
	Rear axle case mounting screw (M10 7T)	48.0 to 55.9 N·m 4.9 to 5.7 kgf·m 35.4 to 41.2 ft-lbs

(1) Plate

(2) Rear Axle Case

W1016209

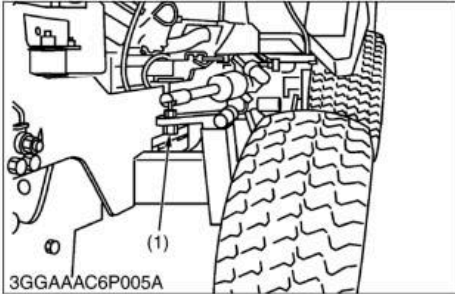

3GGAAAC6P005A

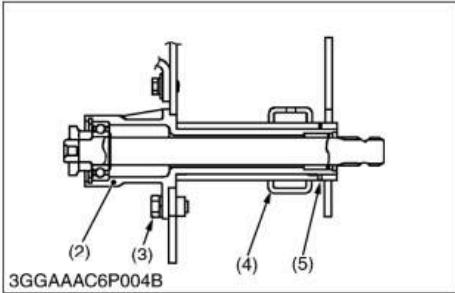

3GGAAAC6P004B

### Separating Front Axle Assembly

1. Remove the rod end mounting nut (1).
2. Support the frame with jacks.
3. Remove the front axle support mounting screws (3).
4. Draw out the front axle support assembly (2) forward.
5. Separate the front axle assembly (4), noting the adjusting shims (5) between the frame and front axle assembly (4).

#### (When reassembling)

- Be sure to install the adjusting shims.
- After reassembling the front axle assembly, inject grease until it comes out.
- Replace the rod end mounting nut with a new one.

#### ■ IMPORTANT

- After assembling the front axle assembly, be sure to adjust the toe-in.

Tightening torque	Rod end mounting nut	108.8 to 130.3 N·m 11.1 to 13.3 kgf·m 80.3 to 96.2 ft·lbs
	Front axle support mounting screws	48.0 to 55.9 N·m 4.9 to 5.7 kgf·m 35.4 to 41.2 ft·lbs

- (1) Rod End Mounting Nut (4) Front Axle Assembly  
 (2) Front Axle Support Assembly (5) Shim  
 (3) Front Axle Support Mounting Screw

W1012044

## (2) Disassembling Front Axle

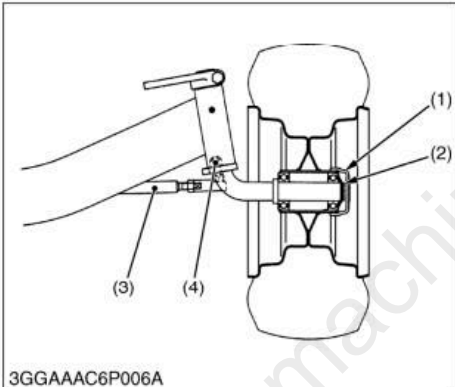

3GGAAAC6P006A

### Front Wheel and Tie Rod

1. Remove the front wheel cap (1).
2. Remove the external snap ring and plain washer (2).
3. Remove the front wheels.
4. Remove the tie-rod mounting lock nuts (4).
5. Remove the tie-rod (3).

#### (When reassembling)

- Replace the tie-rod mounting lock nut with a new one.

#### (Reference)

- L : 584 mm (23.1 in.)

Tightening torque	Tie-rod mounting lock nut	45.1 to 55.9 N·m 4.6 to 5.7 kgf·m 33.4 to 41.2 ft·lbs
-------------------	---------------------------	---

- (1) Front Wheel Cap (3) Tie-rod  
 (2) External Snap Ring and Plain Washer (4) Tie-rod Mounting Lock Nut

W1012423

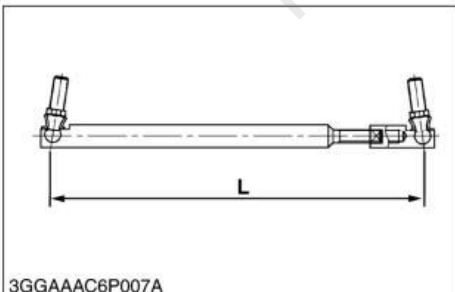

3GGAAAC6P007A

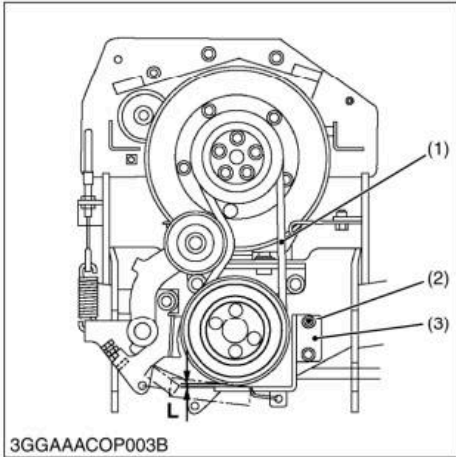

### Adjusting Belt Stay

1. Place the machine on level ground, and stop the engine.
2. Set the PTO clutch lever to “**ENGAGE**” position.
3. Measure the clearance (**L**) between the belt stay (3) and front PTO belt (1).
4. If the measurement is not within the factory specifications, loosen the belt stay mounting screws (2) and move the belt stay (3) to adjust.

Clearance ( <b>L</b> ) between belt stay and front PTO belt	Factory spec.	1.0 to 2.5 mm 0.04 to 0.10 in.
---	---------------	-----------------------------------

- (1) PTO Belt (3) Belt Stay  
(2) Belt Stay Mounting Screw

W1011294

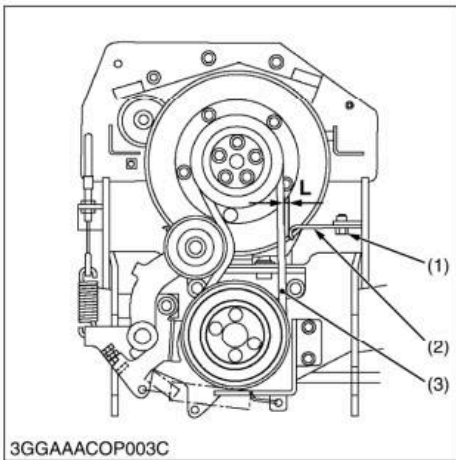

### Adjusting Belt Retainer

1. Place the machine on level ground, and stop the engine.
2. Set the PTO clutch lever to “**ENGAGE**” position.
3. Measure the clearance (**L**) between the belt retainer (2) and front PTO belt (3).
4. If the measurement is not within the factory specifications, loosen the belt retainer mounting screws (1) and move the belt retainer (2) to adjust.

Clearance ( <b>L</b> ) between belt retainer and front PTO belt	Factory spec.	2.0 mm 0.08 in.
---	---------------	--------------------

- (1) Belt Retainer Mounting Screws (3) PTO Belt  
(2) Belt Retainer

W1011549

# Full Version Available

Kubota G21LD Lawn Tractor Workshop Manual

This is a short preview. The complete manual contains all chapters, wiring diagrams, torque specifications and full service procedures.

**VIEW THE FULL MANUAL**

<https://machinecatalogic.com/kubota-g21ld-lawn-tractor-workshop-manual/>