

WSM

WORKSHOP MANUAL
TRACTOR

**L2250, L2550(GST),
L2850(GST), L3250**

Кубота

TROUBLE-SHOOTING

Symptom	Probable Cause	Solution	Reference Page
Engine Does Not Start	<ul style="list-style-type: none"> No fuel Air in the fuel system Water in the fuel system Fuel pipe clogged Fuel filter clogged Excessively high viscosity of fuel or engine oil at low temperature Fuel with low cetane number Fuel leak due to loose injection pipe retaining nut Incorrect injection timing Fuel camshaft worn Injection nozzle clogged Injection pump malfunctioning Fuel transfer pump malfunctioning Seizure of crankshaft, camshaft, piston, cylinder liner or bearing Compression leak from cylinder 	Replenish fuel Vent air Change fuel and repair or flush fuel system Clean Clean or replace Use the specified fuel or engine oil Use the specified fuel Tighten nut Adjust Replace Clean Repair or replace Repair or replace Repair or replace Replace head gasket, tighten cylinder head screw and nut, glow plug and nozzle holder Repair or replace	S.G-2 S.G-21 S.G-21 — S.G-11, 16 S.G-2, 3 S.G-2 S.1-14 S.1-49 S.1-36 S.1-51 S.1-49, 50 — — S.1-15, 17, 18, 19 S.1-31
(Starter Does Not Run)	<ul style="list-style-type: none"> Improper valve seating, valve spring broken, valve seized Improper valve timing Piston ring and liner worn Excessive valve clearance Battery discharged Starter malfunctioning Starter switch malfunctioning Wiring disconnected 	Correct or replace timing gear Replace Adjust Charge Repair or replace Repair or replace Connect	S.1-24 S.1-38, 44 S.1-16 S.9-7 S.9-12, 13 S.9-10,11,12 S.9-10, 11
Engine Revolution is Not Smooth	<ul style="list-style-type: none"> Fuel filter clogged or dirt Air cleaner clogged Fuel leak due to loose injection pipe retaining nut Injection pump malfunctioning Incorrect nozzle opening pressure Injection nozzle stuck or clogged Fuel over flow pipe clogged Governor malfunctioning 	Clean or replace Clean or replace Tighten nut Repair or replace Adjust Repair or replace Clean Repair	S.G-11, 16 S.G-12, 19 S.1-14 S.1-49, 50 S.1-51, 52 S.1-51 — —
Either White or Blue Exhaust Gas is Observed	<ul style="list-style-type: none"> Excessive engine oil Piston ring and liner worn or stuck Incorrect injection timing Deficient compression 	Reduce to the specified level Repair or replace Adjust Adjust top clearance	S.1-3, 6 S.1-38, 44 S.1-49 S.1-29
Either Black or Dark Gray Exhaust Gas is Observed	<ul style="list-style-type: none"> Overload Low grade fuel used Fuel filter clogged Air cleaner clogged 	Lessen the load Use the specified fuel Clean or replace Clean or replace	— S.G-2 S.G-11, 16 S.G-12, 19

[2] MID CASE

DISASSEMBLING AND ASSEMBLING

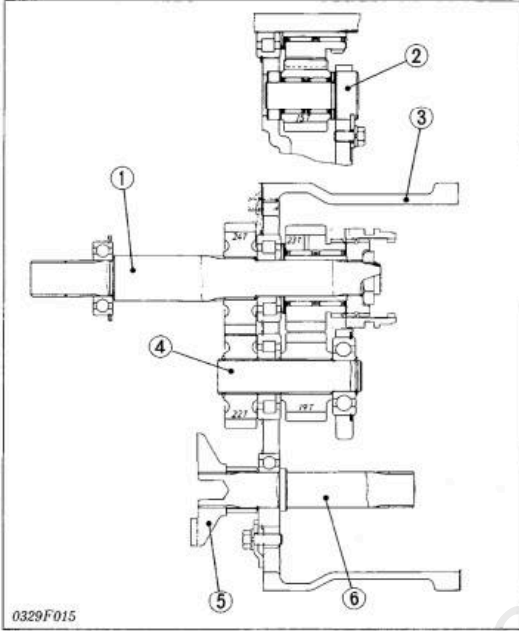

- (1) Counter Shaft 2
- (2) Reverse Shaft 2
- (3) Mid Case
- (4) Reverse Shaft 1
- (5) One-way Clutch (Slant Cam)
[Single Stage Clutch Type]
- (6) PTO Transmitted Shaft
[Single Stage Clutch Type]

Separating Mid Case

- See page S.S-14 to 18.

Counter Shaft 2

1. Remove the stake of staking nut (2) and remove the staking nut.
2. Tap out the counter shaft 2 (1) to the front.

(When reassembling)

■ IMPORTANT

- Be sure to direct the chamfered side of shuttle shifter (7) to the 23T gear side.
- Be sure to install the inner race (4) of bearing (3).
- Install the bearing (3) so that snap ring thereon may face outward as shown in the figure.
- Install the copper washers (9) so that they may not fall between inner race (6) and thrust collar (8) or spline boss 1 (10).
- Direct the grooved side of thrust collar (8) to the 23T gear side.
- After reassembling the counter shaft 2 (1), check that it rotates smoothly.

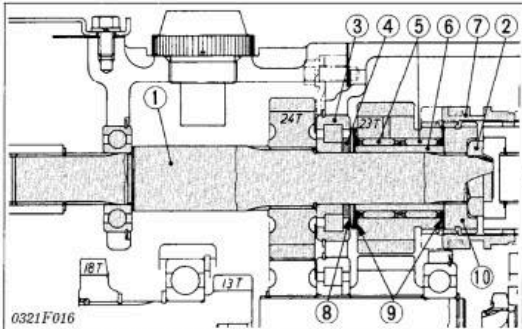
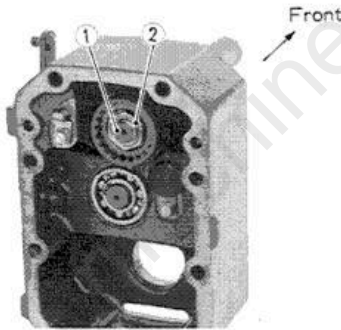

Tightening torque	Staking nut	39.2 to 58.8 N·m 4.0 to 6.0 kgf·m 28.9 to 43.4 ft·lbs
-------------------	-------------	---

- (1) Counter Shaft 2
- (2) Staking Nut
- (3) Bearing
- (4) Inner Race
- (5) Needle Bearing
- (6) Inner Race
- (7) Shuttle Shifter
- (8) Thrust Collar
- (9) Copper Washer
- (10) Spline Boss 1

STEERING

Item		Factory Specification	Allowable Limit
[Manual Steering Type] Steering Wheel	Play	20 to 50 mm 0.79 to 1.97 in.	—
Sector Gear Shaft to Ball Nut	Backlash	0 to 0.33 mm 0 to 0.0130 in.	—
Bevel Gears in Steering Gear Case (14T Bevel Gears)	Backlash	0.1 to 0.3 mm 0.004 to 0.012 in.	0.4 mm 0.016 in.
Adjusting Shim	Thickness	0.8 mm (0.031 in.) 1.0 mm (0.039 in.) 1.2 mm (0.047 in.)	—
Worm Shaft	Turning Torque	Less than 0.98 N·m 0.10 kgf·m 0.72 ft·lbs	—
[Power Steering Type] Steering Wheel	Play	20 to 50 mm 0.79 to 1.97 in.	—
	Operating Force Condition • Engine Speed Approx. 2600 rpm	Less than 5.9 N 0.6 kgf 1.3 lbs	—
Relief Valve	Setting Pressure Condition • Engine Speed Approx. 2600 rpm • Oil Temperature 45 to 55°C 113 to 131°F	11.28 to 11.77 MPa 115 to 120 kgf/cm ² 1636 to 1707 psi	—
Steering Gear Box to Ball Nut	Clearance	0.030 to 0.079 mm 0.00118 to 0.00311 in.	0.15 mm 0.0059 in.
Gear Box Bore	I.D.	61.000 to 61.030 mm 2.40158 to 2.40276 in.	—
Ball Nut	O.D.	60.951 to 60.970 mm 2.39965 to 2.40040 in.	—
Ball Nut Assembly	Axial Play	Less than 0.020 mm 0.00079 in.	—
Worm Shaft	O.D.	24.996 to 25.009 mm 0.98410 to 0.98461 in.	—
Valve Housing to Spool	Clearance	0.008 to 0.015 mm 0.0031 to 0.0059 in.	0.025mm 0.00098 in.

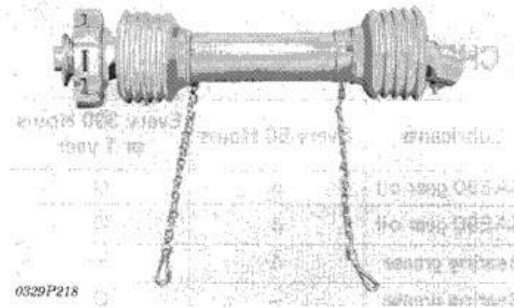

**3) Applying Grease to Universal Joint
(Every 50 Hours)**

1. Apply bearing grease to the two grease nipples until it overflows, and to the sliding portion on universal joint.

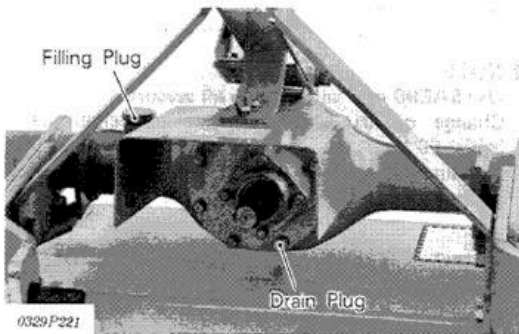

**4) Changing Gear Oil (Rotary Support)
(Initial 50 Hours, Every 300 Hours)**

1. Place an oil pan underneath the rotary support.
2. Remove the oil filling plug.
3. To drain the used oil, remove the drain plug at the bevel gear support and drain the oil completely.
4. Screw in the drain plug.
5. Fill new oil up to the notch on the dipstick.

■ **IMPORTANT**

- Use the proper SAE90 gear oil.

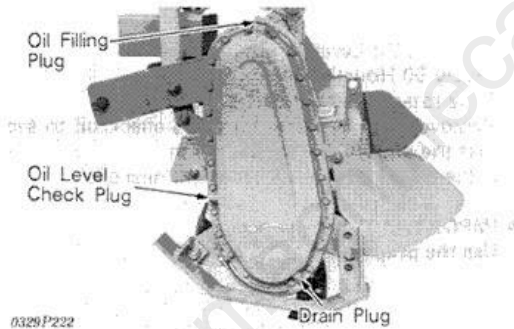

**5) Changing Gear Oil (Chain Case)
(Initial 50 Hours, Every 300 Hours)**

1. Place an oil pan underneath the chain case.
2. Remove the oil filling plug.
3. To drain the used oil, remove the drain plug at the chain case and drain the oil completely.
4. Screw in the drain plug.
5. Fill new oil up to the rim of the check port.

■ **IMPORTANT**

- Use the proper SAE90 gear oil.

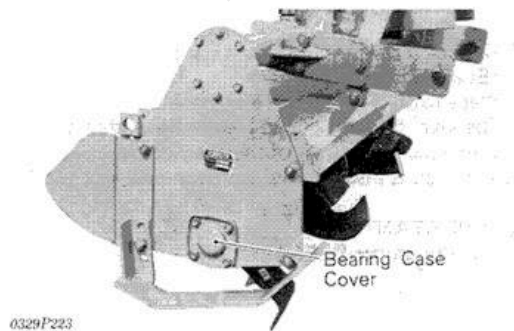

**6) Changing Grease in Bearing Case of Blade Shaft
(Every 300 Hours)**

1. Remove the side frame bearing case cover.
2. Apply bearing grease to bearing case.

Full Version Available

Kubota L3250 Tractor Workshop Manual

This is a short preview. The complete manual contains all chapters, wiring diagrams, torque specifications and full service procedures.

VIEW THE FULL MANUAL

<https://machinecatalogic.com/kubota-l3250-tractor-workshop-manual/>