

# WSM

---

WORKSHOP MANUAL  
**TRACTOR, FRONT LOADER,  
BACKHOE**

**L35 TL720 BT900**

---

**Kubota**

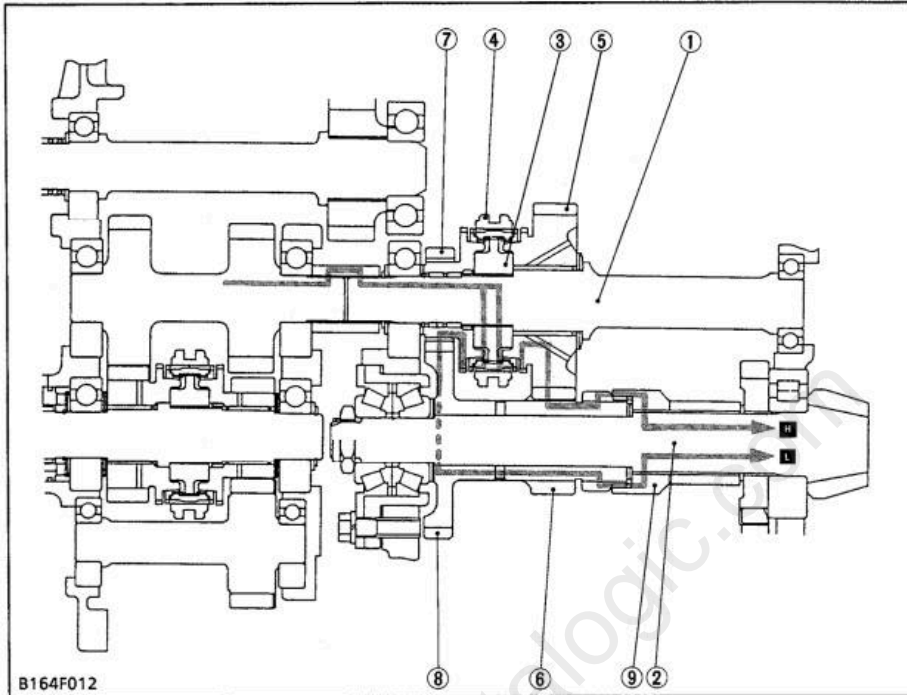
**(3) Hi-Lo Range Shift Section**

- (1) Hi-Lo Shaft
- (2) Spiral Bevel Pinion
- (3) Hub
- (4) Shifter
- (5) 33T Gear
- (6) 16T Gear
- (7) 18T Gear
- (8) 42T Gear
- (9) Coupling

The Hi-Lo range shift section is used synchromesh type system.

Two ways of power flow from the Hi-Lo shaft (1) to the spiral bevel pinion (2) are available by operating the main gear shift lever.

The power is transmitted as follows.

**L** Lo-Range

Hi-Lo Shaft (1) → Hub (3) → Shifter (4) → 18T Gear (7) → 42T Gear (8) → Coupling (9) → Spiral Bevel Pinion (2).

**H** Hi-Range

Hi-Lo Shaft (1) → Hub (3) → Shifter (4) → 33T Gear (5) → 16T Gear (6) → Coupling (9) → Spiral Bevel Pinion (2).

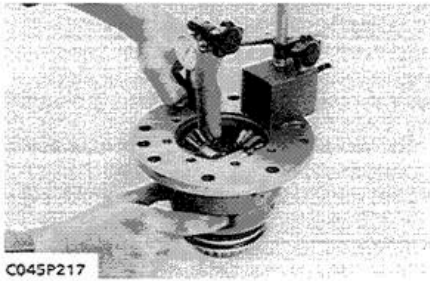

C045P217

#### Backlash between Differential Pinion and Differential Side Gear

1. Set a dial indicator (lever type) on the tooth of the differential pinion.
2. Hold the differential side gear and move the differential pinion to measure the backlash.
3. If the measurement is not within the factory specifications, adjust with the differential side gear washer.

Backlash between differential pinion and differential side gear	Factory spec.	0.15 to 0.30 mm 0.006 to 0.012 in.
	Allowable limit	0.40 mm 0.016 in.

#### (Reference)

- Thickness of differential side gear washers :  
1.5 mm (0.059 in.)  
1.6 mm (0.063 in.)  
1.7 mm (0.067 in.)

## [5] GST VALVE

### CHECKING AND ADJUSTING

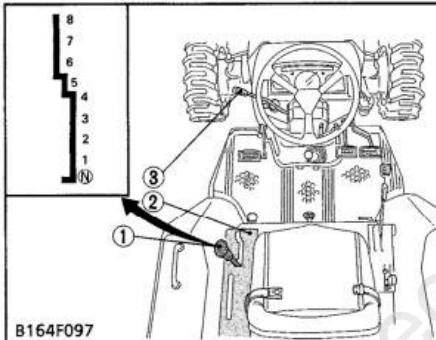

B164F097

#### Checking Shift Cable

1. Check the main shift lever (1) to be "Neutral" position on the main shift lever guide (2).
2. Set the main shift lever (1) and shuttle shift lever (3) to the "Neutral" position.
3. Start the engine, and then shift the shuttle shift lever (3) to "Forward" or "Reverse" position.
4. Check the tractor does not move at main shift lever (1) to be "Neutral" position, and then check the tractor moves when main shift lever (1) is shifted "1st" to "8th" and "8th" to "1st".
5. If any abnormality is present, adjust the shift cable. (Refer to adjusting shift cable.)

(1) Main Shift Lever

(3) Shuttle Shift Lever

(2) Main Shift Lever Guide

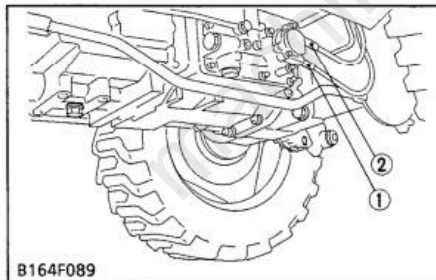

B164F089

#### Adjusting Shift Cable

1. When the tractor moves with the main shift lever at "Neutral" position.
  - Extend the cable adjuster "B" (2) and shorten the cable adjuster "A" (1).
2. When the tractor does not move with the main shift lever at "1st" shift position.
  - Shorten the cable adjuster "B" (2) and extend the cable adjuster "A" (1).
3. After the adjustment, check that "C" portion and "D" portion does not have free play, and then tighten the lock nut (5).

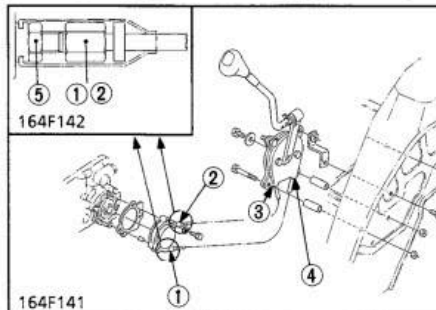

164F142

164F141

(1) Cable Adjustor "A"

(4) "D" Portion

(2) Cable Adjustor "B"

(5) Lock Nut

(3) "C" Portion

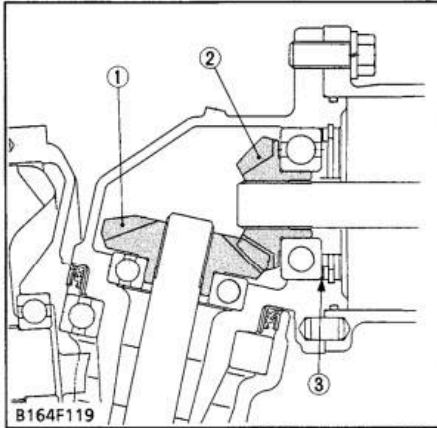

(1) 16T Bevel Gear (3) Shim  
(2) 11T Bevel Gear

#### **Backlash between 11T Bevel Gear and 16T Bevel Gear**

1. Stick a strip of fuse to three spots on the 16T bevel gear (1) with grease.
2. Fix the front axle case, bevel gear case and front gear case.
3. Turn the axle.
4. Remove the bevel gear case from front axle case and measure the thickness of the fuses with an outside micrometer.
5. If the backlash is not within the factory specifications, adjust with shim (3).

Backlash between 11T bevel gear and 16T bevel gear	Factory spec.	0.10 to 0.30 mm 0.0039 to 0.0120 in.
--	---------------	---

#### **(Reference)**

- Thickness of adjusting shims (3) :  
0.8 mm (0.031 in.) 1.2 mm (0.047 in.)  
1.0 mm (0.039 in.)
- Tooth contact : More than 35 %

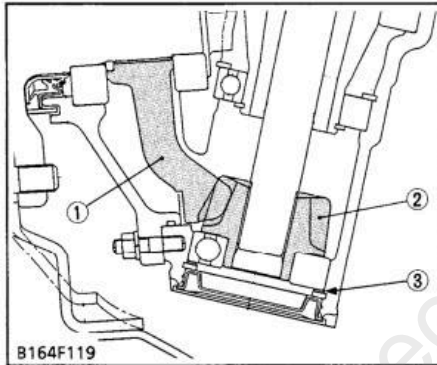

(1) 42T Bevel Gear (3) Shim  
(2) 11T Bevel Gear

#### **Backlash between 11T Bevel Gear and 42T Bevel Gear**

1. Stick a strip of fuse to three spots on the 42T bevel gear (1) with grease.
2. Fix the axle flange and front gear case.
3. Turn the axle.
4. Remove the axle flange from front gear case and measure the thickness of the fuse with an outside micrometer.
5. If the backlash is not within the factory specifications, adjust with shim (3).

Backlash between 11T bevel gear and 42T bevel gear	Factory spec.	0.10 to 0.30 mm 0.0039 to 0.0120 in.
--	---------------	---

#### **(Reference)**

- Thickness of adjusting shims (3) :  
1.0 mm (0.039 in.) 1.8 mm (0.071 in.)  
1.2 mm (0.047 in.) 2.0 mm (0.079 in.)  
1.4 mm (0.055 in.) 2.2 mm (0.087 in.)  
1.6 mm (0.063 in.)
- Tooth contact : More than 35 %

# **F** FRONT LOADER

machinecatalogic.com

# Full Version Available

Kubota L35 Tractor Workshop Manual

This is a short preview. The complete manual contains all chapters, wiring diagrams, torque specifications and full service procedures.

[VIEW THE FULL MANUAL](https://machinecatalogic.com/kubota-l35-tractor-workshop-manual/)

<https://machinecatalogic.com/kubota-l35-tractor-workshop-manual/>