

# WSM

---

WORKSHOP MANUAL  
TRACTOR

L3200, L3800

---

**Kubota**

KISC issued 09, 2020 A

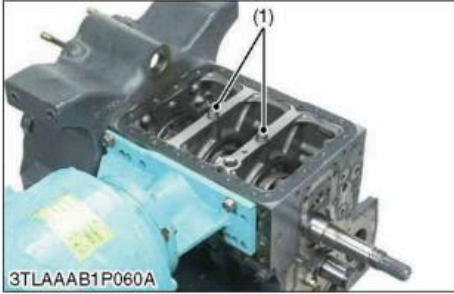

### Crankshaft

#### ■ NOTE

- Before disassembling, check the side clearance of crankshaft. Also check it during reassembling.

1. Remove the main bearing case screw 2 (1).
2. Pull out the crankshaft assembly, taking care not to damage the crankshaft bearing 1.

#### (When reassembling)

#### ■ IMPORTANT

- Install the crankshaft sub assembly, aligning the screw hole of main bearing case 2 with the screw hole of cylinder block.
- When tightening the main bearing case screw 2, apply oil to the screw and screw by hand before tightening the specific torque.

If not smooth to screw by hand, align the screw holes between the cylinder block and the main bearing case.

Tightening torque	Main bearing case screws 2	69 to 73 N·m 7.0 to 7.5 kgf·m 51 to 54 lbf·ft
-------------------	-------------------------------	---

(1) Main Bearing Case Screw 2

9Y1210625ENS0074US0

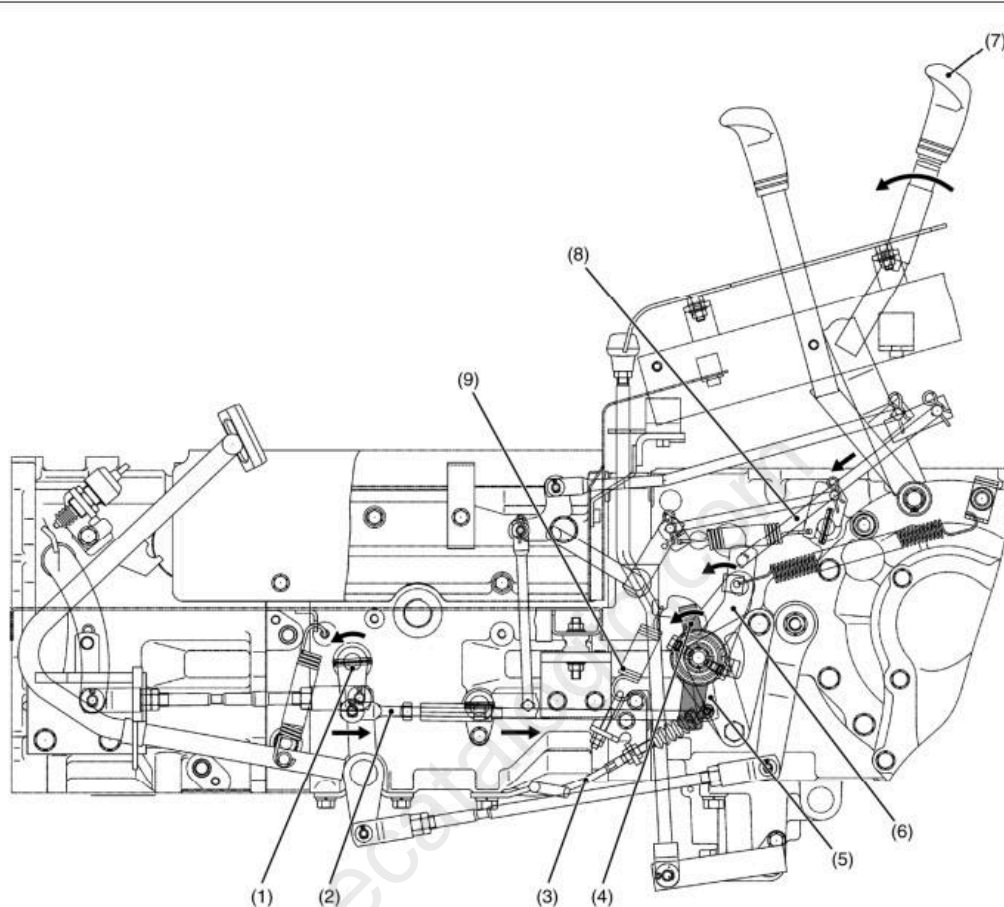
**[3] CRUISE CONTROL (OPTION)**

3TLAAB3P077A

- |                          |                    |                          |                    |
|--------------------------|--------------------|--------------------------|--------------------|
| (1) Connecting Shaft     | (4) Cruise Lever 1 | (6) Cruise Lever 2       | (8) Lever Rod      |
| (2) Cruise Adjusting Rod | (5) Release Lever  | (7) Cruise Control Lever | (9) Release Spring |
| (3) Release Wire         |                    |                          |                    |

The cruise control lever (7) and HST pedal are linked with the lever rod (8), cruise lever 1 (4), cruise lever 2 (6), cruise adjusting rod (2) and connecting shaft (1).

When the cruise control lever (7) is moved to forward direction, cruise lever 2 (6) is moved to arrow direction by the lever rod (8). The cruise lever 1 (4) is moved forward by being pushed to the cruise lever 2 (6), and cruise adjusting rod (2) is pulled backward. Because cruise adjusting rod (2) and the HST pedal are connected by the connecting shaft (1), the HST pedal is moved and HST becomes forward position.

The cruise control can be returned to neutral automatically when brake pedals are depressed.

When brake pedals are depressed, release wire pull the release lever (5) to forward.

As result, the holding force of cruise control lever (7) is lost and the cruise control lever (7) return to neutrality by force of release spring (9).

9Y1210625TRM0020US0

# 6. DISASSEMBLING AND ASSEMBLING

## [1] MANUAL TRANSMISSION TYPE

### (1) Clutch Housing Case



#### Speed Change Cover

1. Remove the speed change cover (1).

#### **(When reassembling)**

- Apply liquid gasket (Three Bond 1206C or equivalent) to joint face of speed change cover and clutch housing.

Tightening torque	Speed change cover mounting screw	24 to 27 N·m 2.4 to 2.8 kgf·m 18 to 20 lbf·ft
-------------------	-----------------------------------	---

(1) Speed Change Cover

9Y1210625TRS0049US0

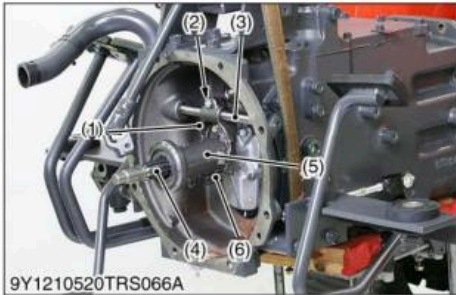

#### Release Hub and Clutch Lever (L3200)

1. Remove the release fork (1) mounting screw (2).
2. Draw out the clutch lever (3) to remove the release fork (1).
3. Remove the hub return spring (6).
4. Remove the thrust ball bearing (4) and release hub (5) as a unit.

#### **(When reassembling)**

- Make sure the direction of the release fork (1) is correct.
- Inject grease to the release hub (5).
- Be sure to set the hub return spring (6).

Tightening torque	Release fork mounting screw	24 to 27 N·m 2.4 to 2.8 kgf·m 18 to 20 lbf·ft
-------------------	-----------------------------	---

(1) Release Fork  
(2) Screw  
(3) Clutch Lever

(4) Thrust Ball Bearing  
(5) Release Hub  
(6) Hub Return Spring

9Y1210625TRS0050US0

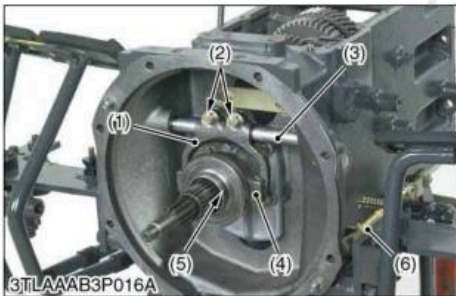

#### Release Hub and Clutch Lever (L3800)

1. Remove the clutch rod (6).
2. Remove the release fork setting screws (2).
3. Remove the thrust ball bearing (5) and release hub (4) as a unit.
4. Draw out the clutch lever (3).
5. Remove the release fork (1).

#### **(When reassembling)**

- Make sure the direction of the release fork is correct.
- Inject grease to the release hub.
- Apply grease to the contact surfaces of the release fork and release hub.
- Apply grease on the clutch lever.

Tightening torque	Release fork mounting screw	24 to 27 N·m 2.4 to 2.8 kgf·m 18 to 20 lbf·ft
-------------------	-----------------------------	---

(1) Release Fork  
(2) Screw  
(3) Clutch Lever

(4) Release Hub  
(5) Thrust Ball Bearing  
(6) Clutch Rod

9Y1210625TRS0051US0

### 3. TIGHTENING TORQUES

Tightening torques of screws, bolts and nuts on the table below are especially specified.  
(For general use screws, bolts and nuts: See page "5. TIGHTENING TORQUES" on page G-11.)

Item	N·m	kgf·m	lbf·ft
Safety valve assembly	40 to 49	4.0 to 5.0	29 to 36
Safety valve lock nut	59 to 78	6.0 to 8.0	44 to 57
Delivery pipe joint screw	49 to 68	5.0 to 7.0	37 to 50
Hydraulic pump assembly mounting screw and nut	24 to 27	2.4 to 2.8	18 to 20
Pump cover mounting screw	40 to 44	4.0 to 4.5	29 to 32
Hydraulic cylinder assembly mounting stud bolts	30 to 49	3.0 to 5.0	22 to 36
Hydraulic cylinder assembly mounting screws and nuts	78 to 90	7.9 to 9.2	58 to 66
Position control valve mounting screws	24 to 27	2.4 to 2.8	18 to 20
Plug 1	40 to 58	4.0 to 6.0	29 to 43
Plug 2	30 to 49	3.0 to 5.0	22 to 36
Unload plug	40 to 58	4.0 to 6.0	29 to 43
Relief valve plug	49 to 68	5.0 to 7.0	37 to 50
Lock nut	59 to 78	6.0 to 8.0	44 to 57

9Y1210625HYS0003US0

# Full Version Available

Kubota L3800 Tractor Workshop Manual

This is a short preview. The complete manual contains all chapters, wiring diagrams, torque specifications and full service procedures.

**VIEW THE FULL MANUAL**

<https://machinecatalogic.com/kubota-l3800-tractor-workshop-manual/>