

WSM

WORKSHOP MANUAL
FRONT LOADER

LA1301, LA1601

Kubota

[1] FEATURES

17010F00030

- (1) Parallel link mechanism for easy lifting and lowering.
- (2) Tiltable remote control stand for the easy-to-operate lever position in cabin.
- (3) Series circuit for simultaneous operation, and bucket confluence circuit for quick dumping.
- (4) Detachable pin and stand for easy mounting and dismounting.
- (5) Bucket link for greater scooping and dumping angles.
- (6) Readily attachable with front weight bracket.
- (7) Standard equipped with quick attachment hitch.
- (8) One-lever operation.

17010M00010

[4] MAINTENANCE CHECK LIST

To keep the machine working in good condition as well as to avoid any accident and trouble, carry out periodic inspection and maintenance. Check the following points before use.

Service Interval	Check Points	Reference Page
Daily (Each use)	<ul style="list-style-type: none"> • Check the transmission fluid level • Check the hydraulic hoses 	S-2 S-2
Every 10 hours	<ul style="list-style-type: none"> • Grease all grease fittings • Lubricate joints of control lever linkage 	S-3 S-3

17010G00030

[5] CHECK AND MAINTENANCE

⚠ CAUTION

- When checking and repairing, park the tractor on flat ground and apply the parking brake.
- When checking and repairing, lower the bucket and stop the engine.

12210S00040

(1) Check Points of Each Use or Daily

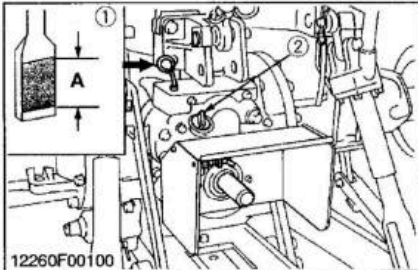

12260F00100

Checking Transmission Fluid Level

1. To check the oil level, draw out the dipstick, wipe it clean, replace it, and draw it out again. Check to see that the oil level lies between the two notches.
2. If the level is too low, add new oil to the prescribed level at the oil inlet.

■ IMPORTANT

- If oil level is low, do not run engine.

Transmission fluid capacity (Front loader is not attached)	M-110	55.0 L 58.1 U.S.qts. 48.4 Imp.qts.
	M-120	58.0 L 61.3 U.S.qts. 51.0 Imp.qts.

- (1) Dipstick
(2) Oil Filling Plug

A: Oil level is acceptable within this range.

17010G00040

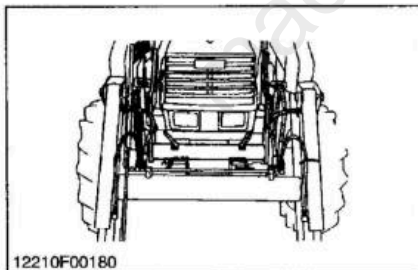

12210F00180

Checking Hydraulic Hoses

1. Check all hydraulic hoses for cuts or wear.
2. If defects are found, replace them.

12210S00060

SERVICING SPECIFICATIONS

Item	Factory Specification	Allowable Limit
Relief Valve Condition <ul style="list-style-type: none"> • Engine Speed Maximum • Oil Temperature 45 to 55 °C 113 to 131 °F 	Setting Pressure 20.3 to 20.7 MPa 207 to 211 kgf/cm ² 2950 to 3000 psi	—
Piston Rod	Bend	— 0.25 mm 0.0098 in.

17010S00020

TIGHTENING TORQUES

[1] GENERAL USE SCREWS, BOLTS AND NUTS

Screws, bolts and nuts whose tightening torques are not specified in this Workshop Manual should be tightened according to the table below.

American standard cap screws with UNC or UNF threads				Metric cap screws					
Grade	SAE 5 or 8			Grade	Property class 8.8 (Approx. SAE grade 5)				
Size	Unit	N-m	kgf-m	ft-lbs	Size	Unit	N-m	kgf-m	ft-lbs
1/4		9.8 to 11.7	1.0 to 1.2	7.2 to 8.6	M6		9.8 to 11.2	1.0 to 1.1	7.2 to 8.3
5/16		19.0 to 23.1	1.9 to 2.4	14 to 17	M8		23.6 to 27.4	2.4 to 2.8	17.4 to 20.2
3/8		33.9 to 40.7	3.5 to 4.2	25 to 30	M10		48.1 to 55.8	4.9 to 5.7	35.5 to 41.2
1/2		88.1 to 105.8	9.0 to 10.8	65 to 78	M12		77.5 to 90.1	7.9 to 9.2	57.2 to 66.5
9/16		122.0 to 146.4	12.4 to 14.9	90 to 108	M14		124 to 147	12.6 to 15.0	91.2 to 108
5/8		176.3 to 211.5	18.0 to 21.6	130 to 156	M16		196 to 225	20.0 to 23.0	145 to 166
—		—	—	—	M18		275 to 318	28.0 to 32.5	203 to 235

12210S00110

[2] HYDRAULIC FITTINGS

Item	Thread size	Tightening torque		
		N-m	kgf-m	ft-lbs
Adjustable elbow and adapter	9/16	37 to 44	3.7 to 4.6	27 to 33
	3/4	47 to 54	4.8 to 5.5	35 to 40
	7/8	77 to 85	7.9 to 8.7	57 to 63
Hose fitting and flare nut	9/16	22 to 25	2.2 to 2.6	16 to 19
	3/4	35 to 41	3.6 to 4.1	26 to 30
	7/8	65 to 71	6.6 to 7.2	48 to 52
	1/4	30 to 35	3.1 to 3.6	22 to 26
Adapter (NPT)	3/8	39 to 44	3.9 to 4.4	28 to 32
	1/2	49 to 58	5.0 to 5.9	36 to 43

NOTE : When connecting a hose with flare nut, after tightening the nut with specified torque, return it approximately 0.79 rad. (45 deg.) and re-tighten it to specified torque.

17010S00030

(3) Disassembling Controller

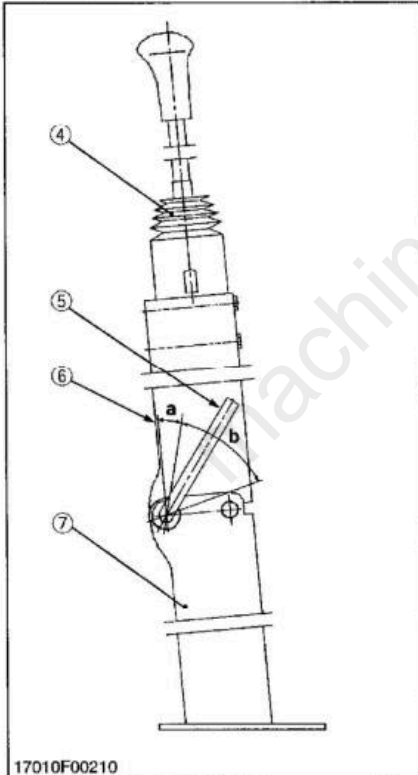
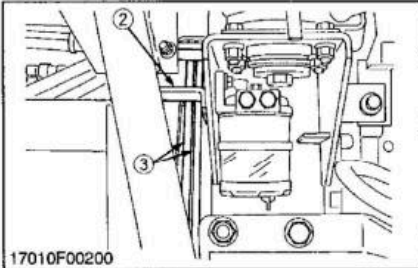
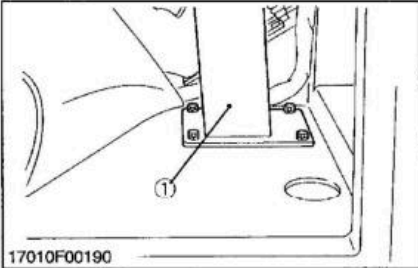

Controller Stand

1. Remove the controller stand assembly (1) with the cables (3) from the cabin floor.
2. Remove the controller (4) with the cables (3) from the controller stand 2 (6).
3. Remove the bolt, 3/8" lock nut, nut and lock lever (5).
4. Remove the controller stand 2 (6) from the controller stand 1 (7).

(When reassembling)

- When installing the controller stand 1 (7) and 2 (6), adjust the direction of 1/2" nut so that the lock lever (5) should be located with 1.05 rad. (60°). After hand tightening as shown in the figure.
- When installing the controller stand 1 (7) and 2 (6), the controller stand 2 (6) should be rotated by hand.
- Attach the controller stand assembly (1) to the cabin floor after routing the cables (3) through the holes on the cabin floor and cabin bracket (2).

Tightening torque	3/8" lock nut	15 to 20 N·m 1.5 to 2.1 kgf·m 11 to 15 ft·lbs
-------------------	---------------	---

- (1) Controller Stand Assembly
 - (2) Cabin Bracket
 - (3) Cable
 - (4) Controller
 - (5) Lock Lever
 - (6) Controller Stand 2
 - (7) Controller Stand 1
- a : 0.26 rad. (15°)
b : 1.05 rad. (60°)

Full Version Available

Kubota LA1601 Front Loader Workshop Manual

This is a short preview. The complete manual contains all chapters, wiring diagrams, torque specifications and full service procedures.

VIEW THE FULL MANUAL

<https://machinecatalogic.com/kubota-la1601-front-loader-workshop-manual/>