

# WSM

---

WORKSHOP MANUAL  
**FRONT LOADER**

**LA1953AU, LA2253AU**

---

**Kubota**

**Self-leveling on Boom Up (Figure 4)**

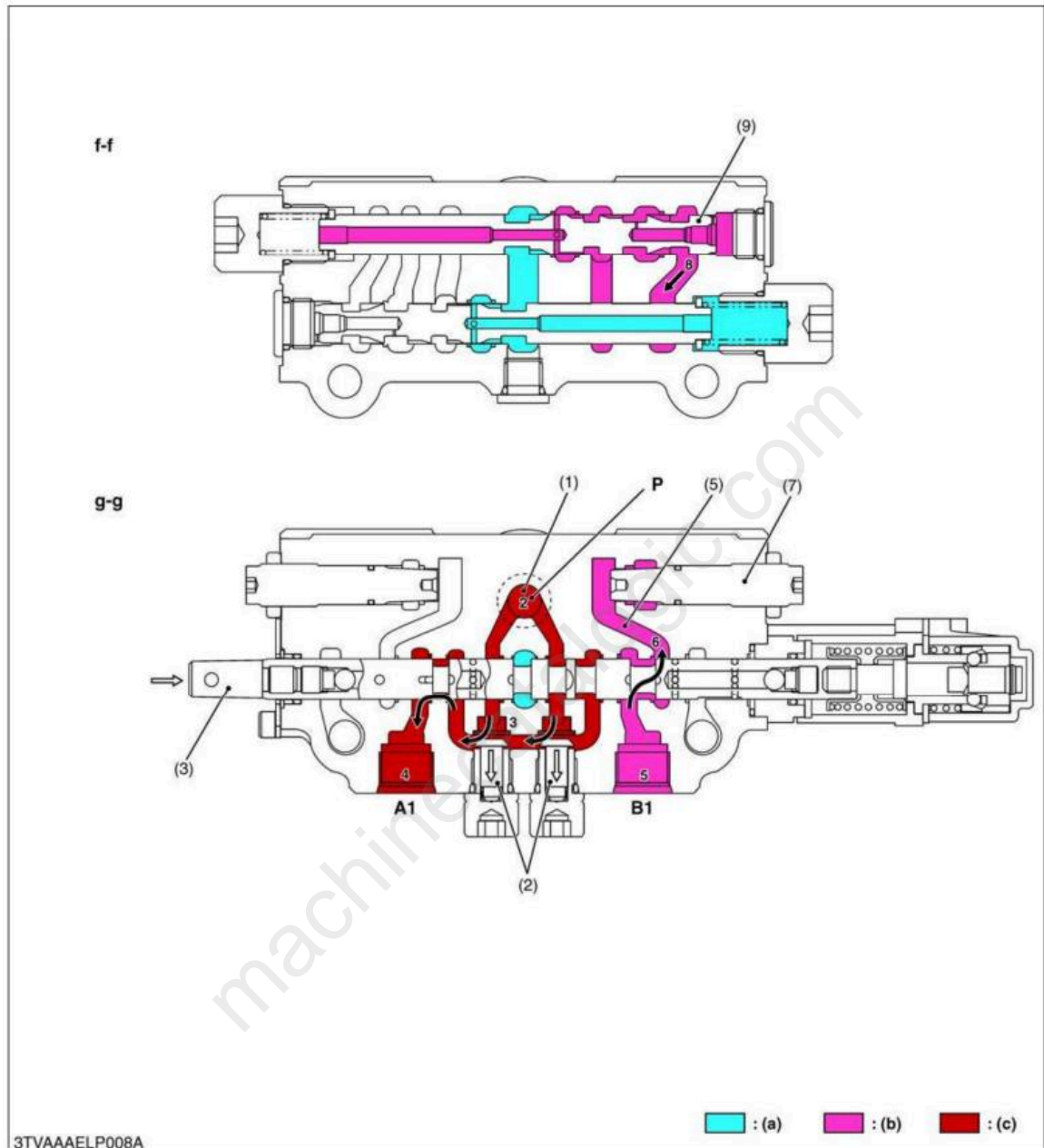

- (1) P Port
- (2) Load Check Valve
- (3) Boom Spool
- (4) Passage A
- (5) Raising Adjuster
- (6) Raising Divider Spool
- (7) A1 Port (Connected Boom Cylinder Bottom Side)
- (8) B1 Port (Connected Boom Cylinder Rod Side)
- (9) P Port (Pump Port)

- (a) Low Pressure
- (b) Middle Pressure
- (c) High Pressure
- 1 to 22 : Oil Flow

- f-f : Divider Section
- g-g : Boom Section

9Y1210547FLM0019US0

**Boom Floating (Figure 4)**

f-f

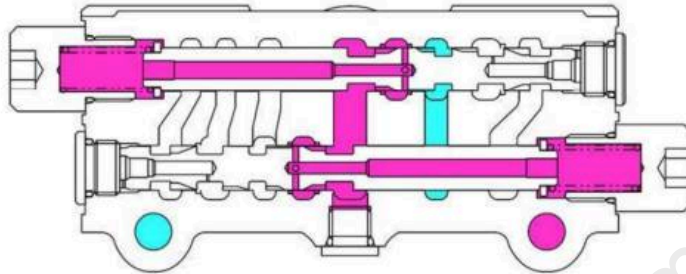

g-g

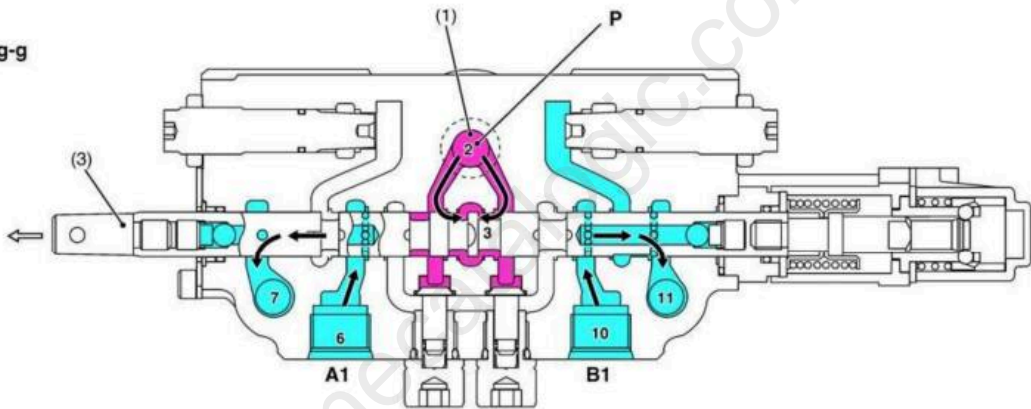

3TVAAAELP037A

■ : (a)    ■ : (b)

- (1) P Port
- (3) Boom Spool

**A1 : A1 Port (Connected Boom Cylinder Bottom Side)**  
**B1 : B1 Port (Connected Boom Cylinder Rod Side)**

**P : P Port (Pump Port)**  
**f-f : Divider Section**  
**g-g : Boom Section**

**(a) Low Pressure**  
**(b) Middle Pressure**  
**1 to 14 : Oil Flow**

9Y1210547FLM0034US0

## [2] SPILL GUARD LINK

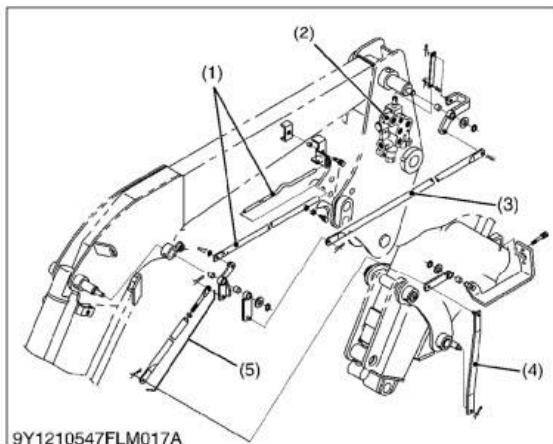

9Y1210547FLM017A

The spill guard linkage consists of connecting rod 1 (4), connecting rod 2 (5) and connecting rod 3 (3). They are connected to the bucket, boom and spill guard valve (2).

This linkage is moved by movement of boom and bucket and operates the spill guard valve (2)

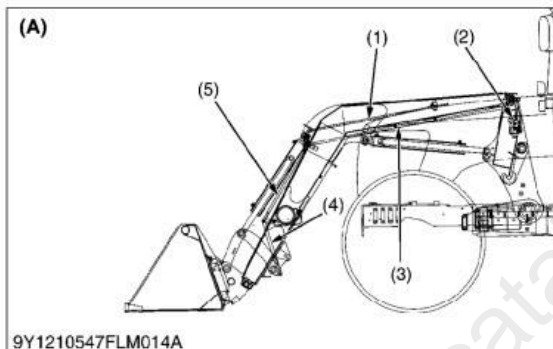

9Y1210547FLM014A

### ■ Bucket on the Ground

In the first condition **(A)**, the loader bucket is on the ground and the spill guard linkage does NOT press the spill guard valve (5) spool.

When the operator operates the control lever to roll back or boom up at this position, there is no restriction for their movement

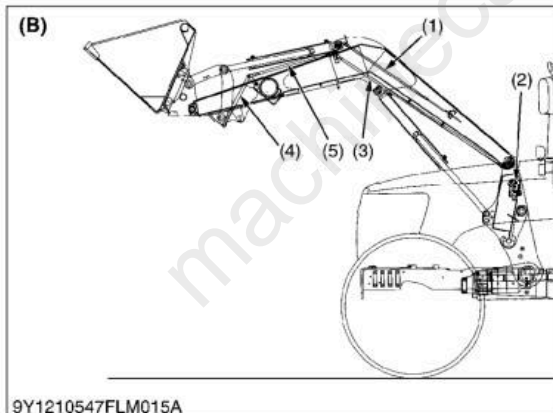

9Y1210547FLM015A

### ■ Boom Up and Bucket Roll-back

In the second condition **(B)**, the loader boom raises and the loader bucket rolls back.

At this time, the spill guard linkage starts pressing the spill guard valve (5) spool.

When the operator operates the control lever to roll back or boom up at this position, the bucket can roll back or the boom can raise but its movement is slower than above condition

- (1) Bucket Level Indicator
- (2) Spill Guard Valve
- (3) Connecting Rod 3
- (4) Connecting Rod 1
- (5) Connecting Rod 2

- (A) Bucket on the Ground**
- (B) Boom Up and Bucket Roll-back**

**(To be continued)**

## [2] HYDRAULIC HOSE

### (1) Standard Type

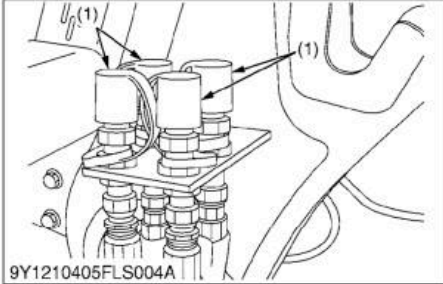

#### Hydraulic Hoses

1. Slowly release all hydraulic pressure by moving the hydraulic control lever in all directions.
2. Disconnect the four hoses with quick couplers at the control valve and place them on the right side of the boom.
3. Place the protective caps and plugs on the quick coupler ends.
4. Start the engine and slowly back the tractor away from the loader.

(1) Protective Plug

9Y1210547FLS0024US0

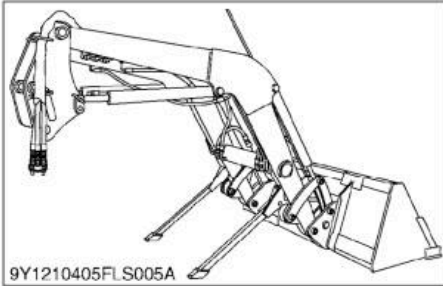

# Full Version Available

Kubota LA2253AU Front Loader Workshop Manual

This is a short preview. The complete manual contains all chapters, wiring diagrams, torque specifications and full service procedures.

**VIEW THE FULL MANUAL**

<https://machinecatalogic.com/kubota-la2253au-front-loader-workshop-manual/>