

WSM

WORKSHOP MANUAL
FRONT LOADER

LA524AU-B, LA714AU-B,
LA854AU-B

Kubota

4. TIGHTENING TORQUES

[1] GENERAL USE SCREWS, BOLTS AND NUTS (FOR FRONT LOADER)

Screws, bolts and nuts whose tightening torques are not specified in this Workshop Manual should be tightened according to the table below.

Indication on top of bolt	⬡ 4 No-grade or 4T						⬡ 7 ⬡ 8.8 7T or Property class 8.8						⬡ 9 ⬡ 10.9 9T or Property class 10.9		
	Ordinariness			Aluminum			Ordinariness			Aluminum			Ordinariness		
Material of opponent part	Ordinariness			Aluminum			Ordinariness			Aluminum			Ordinariness		
Unit	N-m	kgf-m	lbf-ft	N-m	kgf-m	lbf-ft	N-m	kgf-m	lbf-ft	N-m	kgf-m	lbf-ft	N-m	kgf-m	lbf-ft
M6 (6 mm, 0.24 in.)	7.9 to 9.3	0.80 to 0.95	5.8 to 6.8	7.9 to 8.8	0.80 to 0.90	5.8 to 6.5	9.81 to 11.2	1.00 to 1.15	7.24 to 8.31	7.9 to 8.8	0.80 to 0.90	5.8 to 6.5	12.3 to 14.2	1.25 to 1.45	9.05 to 10.4
M8 (8 mm, 0.31 in.)	18 to 20	1.8 to 2.1	13 to 15	17 to 19	1.7 to 2.0	13 to 14	24 to 27	2.4 to 2.8	18 to 20	18 to 20	1.8 to 2.1	13 to 15	30 to 34	3.0 to 3.5	22 to 25
M10 (10 mm, 0.39 in.)	40 to 45	4.0 to 4.6	29 to 33	32 to 34	3.2 to 3.5	24 to 25	48 to 55	4.9 to 5.7	36 to 41	40 to 44	4.0 to 4.5	29 to 32	61 to 70	6.2 to 7.2	45 to 52
M12 (12 mm, 0.47 in.)	63 to 72	6.4 to 7.4	47 to 53	-	-	-	78 to 90	7.9 to 9.2	58 to 66	63 to 72	6.4 to 7.4	47 to 53	103 to 117	10.5 to 12.0	76.0 to 86.7
M14 (14 mm, 0.55 in.)	108 to 125	11.0 to 12.8	79.6 to 92.5	-	-	-	124 to 147	12.6 to 15.0	91.2 to 108	-	-	-	167 to 196	17.0 to 20.0	123 to 144
M16 (16 mm, 0.63 in.)	167 to 191	17.0 to 19.5	123 to 141	-	-	-	197 to 225	20.0 to 23.0	145 to 166	-	-	-	260 to 304	26.5 to 31.0	192 to 224
M18 (18 mm, 0.71 in.)	246 to 284	25.0 to 29.0	181 to 209	-	-	-	275 to 318	28.0 to 32.5	203 to 235	-	-	-	344 to 402	35.0 to 41.0	254 to 296
M20 (20 mm, 0.79 in.)	334 to 392	34.0 to 40.0	246 to 289	-	-	-	368 to 431	37.5 to 44.0	272 to 318	-	-	-	491 to 568	50.0 to 58.0	362 to 419

WSM000001GEG0006US0

[2] STUD BOLTS

Material of opponent part	Ordinariness			Aluminum		
Unit	N-m	kgf-m	lbf-ft	N-m	kgf-m	lbf-ft
M8 (8 mm, 0.31 in.)	12 to 15	1.2 to 1.6	8.7 to 11	8.9 to 11	0.90 to 1.2	6.5 to 8.6
M10 (10 mm, 0.39 in.)	25 to 31	2.5 to 3.2	18 to 23	20 to 25	2.0 to 2.6	15 to 18
M12 (12 mm, 0.47 in.)	30 to 49	3.0 to 5.0	22 to 36	31	3.2	23
M14 (14 mm, 0.55 in.)	62 to 73	6.3 to 7.5	46 to 54	-	-	-
M16 (16 mm, 0.63 in.)	98.1 to 112	10.0 to 11.5	72.4 to 83.1	-	-	-
M18 (18 mm, 0.71 in.)	172 to 201	17.5 to 20.5	127 to 148	-	-	-

WSM000001GEG0007US0

2. CONTROL VALVE ASSEMBLY

[1] STRUCTURE

LA524AU-B

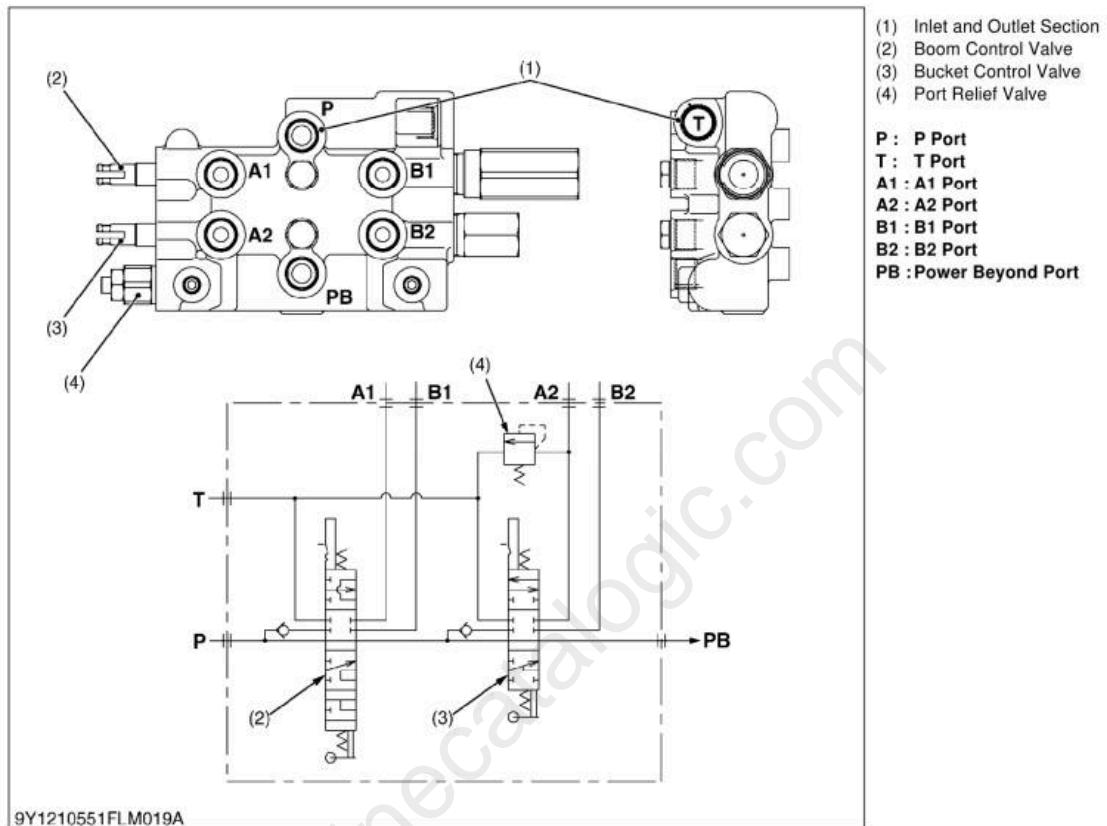

The control valve assembly is composed of one casting block and four major sections as shown above.

(1) Inlet and Outlet Section

P port and **T** port are in this section.

The **P** port is connected to the **OUTLET** port of hydraulic block by the hydraulic hose.

The **T** port is connected to the **TANK** port of hydraulic block by the hydraulic hose.

(2) Boom Control Section

The boom control valve is of 4-position, 6-connection, detente, spring center type spool, consisting of a mono block valve housing, load check valve, etc. This valve connects to **A1** and **B1** ports and controls oil flow to the boom cylinder.

(3) Bucket Control Section

The bucket control valve is of 3-position, 6-connection, no detente, spring center type spool, consisting of a mono block valve housing, load check valve, etc. This valve connects to **A2** and **B2** ports and controls oil flow to the bucket cylinder.

(4) Power Beyond

This section includes **PB** port which is connected to the **INLET** port of hydraulic block by the hydraulic hose, and feeds oil to the 3P hydraulic control valve.

9Y1210551FLM0025US0

"DUMP" Position

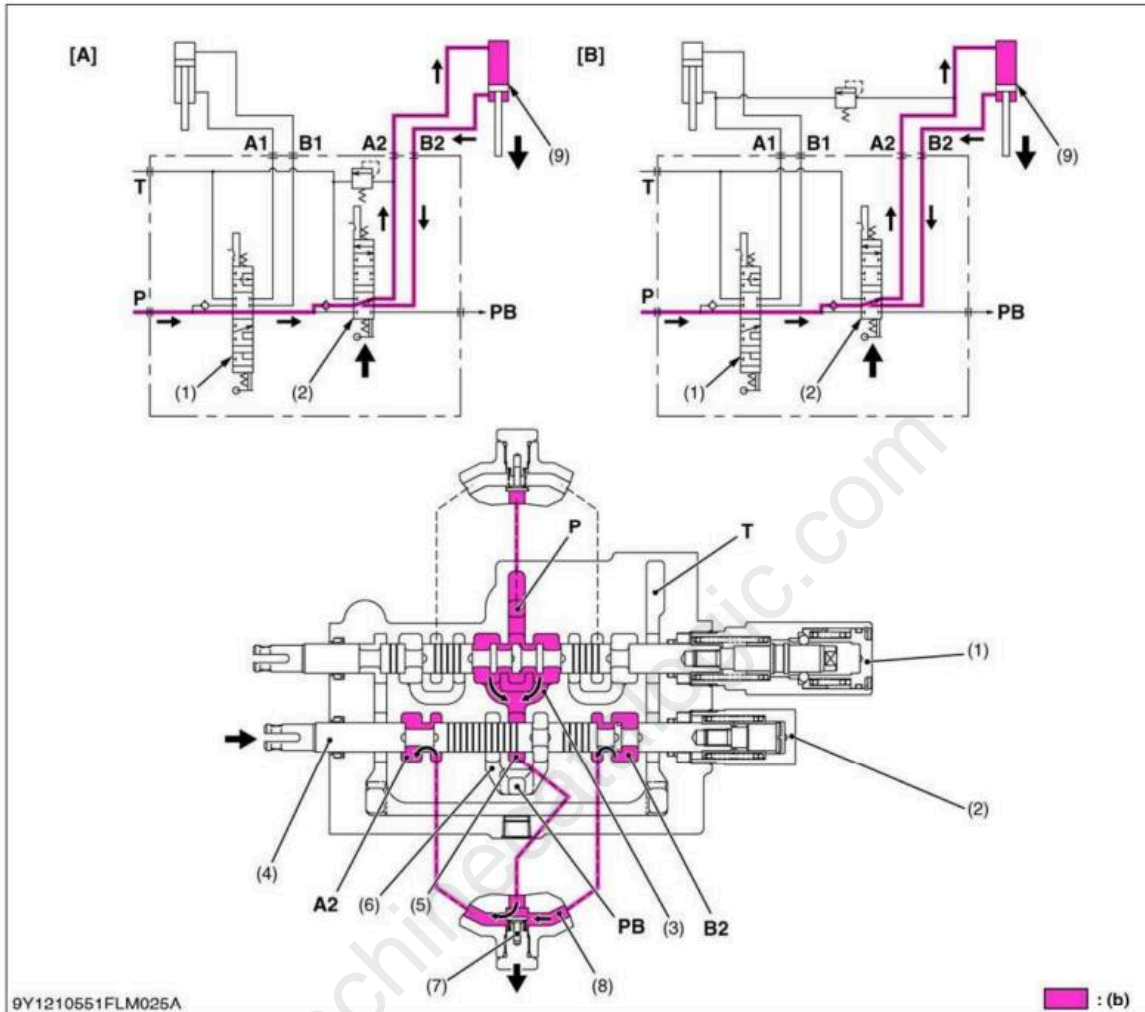

9Y1210551FLM025A

(b) : High Pressure Oil

- | | | | |
|----------------------------|----------------------|-------------------------------|--------------------------|
| (1) Boom Control Section | (7) Load Check Valve | PB : Power Beyond Port | (b) High Pressure Oil |
| (2) Bucket Control Section | (8) Passage 2 | A2 : A2 Port | [A] LA524AU-B |
| (3) PB Passage 1 | (9) Bucket Cylinder | (From Bucket Cylinder) | [B] LA714AU-B, LA854AU-B |
| (4) Spool (Bucket) | | B2 : B2 Port | |
| (5) Neutral Passage 2 | | (To Bucket Cylinder) | |
| (6) PB Passage 2 | P : P Port | | |
| | T : T Port | | |

- When the operator dumps the bucket, the spool (bucket) (4) of the bucket control section (2) is pushed into the loader control valve. Thus it forms oil passage between passage 2 (8) and, **A2** port and **B2** port.
- The pressure-fed oil from the **P** port flows through the boom control valve, opens the load check valve, and flows through the notched section of the spool and **A2** port to the bucket cylinder to extend the cylinder.
- Return oil from the bucket cylinder (9) flows from the **B2** port to the passage 2 (8), and flows to the **A2** port together with the pressure-fed oil from the **P** port.
As a result, the dump speed is increased.

(Reference)

- The oil pressure of the **A2** port and **B2** port is identical, but the bucket cylinder is extended by the difference of received pressure area (cylinder rod part).

9Y1210551FLM0037US0

Full Version Available

Kubota LA854AU-B Front Loader Workshop Manual

This is a short preview. The complete manual contains all chapters, wiring diagrams, torque specifications and full service procedures.

VIEW THE FULL MANUAL

<https://machinecatalogic.com/kubota-la854au-b-front-loader-workshop-manual/>