

WSM

WORKSHOP MANUAL
TRACTOR

M100X, M110X, M126X, M135X

Kubota

1. TRAVELING CLUTCH

[1] STRUCTURE

(1) Master Clutch (Forward and Reverse)

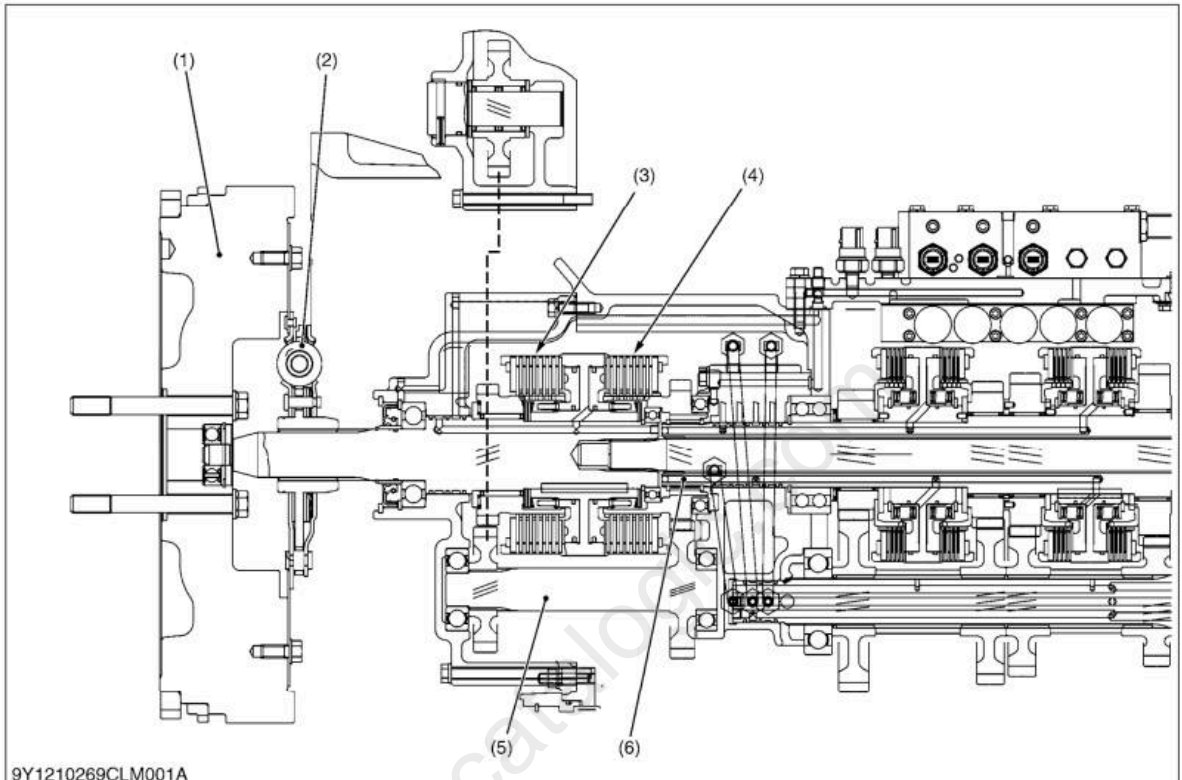

(1) Flywheel
(2) Damper Disc

(3) Master Clutch (Reverse)
(4) Master Clutch (Forward)

(5) Gear Shaft

(6) 1st Shaft

The master clutch is composed of forward and reverse hydraulic clutches, and the hydraulic clutches are switched over by turning on and off the solenoid valve.

A pressure of oil into the clutch is controlled by the solenoid proportional pressure reducing valve, allowing smooth engagement of the clutch.

By controlling pressure of the master clutch with an solenoid proportional reducing valve, the operation feels like a mechanical clutch.

On the other hand, operating the shuttle lever controls the master clutch to switch between forward and reverse.

■ Clutch Engaged

When the shuttle lever is operated, the solenoid proportional reducing valve is operated with the Main ECU. The clutch pressure is raised and master clutch is engaged.

In clutch pedal operation, the position of clutch pedal is detected with clutch pedal sensor electrically and the signal is sent to the microcomputer, then the microcomputer operates the solenoid proportional reducing valve to send the oil for master clutch and master clutch is engaged.

■ Clutch Disengaged

When shuttle lever is returned to neutral position, the solenoid valve is turned off. The oil in the master clutch is opened to the transmission and master clutch is disengaged.

On the other hand, when depressing the clutch pedal end of clutch safety valve, clutch valve is opened and oil in the master clutch back into the transmission case.

Therefore master clutch is disengaged.

And also the master clutch can be disengaged using the clutch button on the power shift lever.

9Y1210525CLM0001US0

MECHANISM

CONTENTS

1. STRUCTURE.....	5-M1
-------------------	------

machinecatalogic.com

(Continued)

This figure shows the hydraulic circuit for the front suspension system.

Fluid is delivered from the hydraulic pump (8) to the regulator valve (4), and then fluid is distributed to seven flow lines at the regulator valve (4). Fluid supplies to the front suspension system by two of seven flow lines.

1) Main fluid line for extending and retracting cylinder

Main fluid flows to the suspension valve (2) through the flow priority valve (3). Main fluid's pressure is restricted by the main relief valve (1).

2) Pilot fluid line for controlling the suspension valves (2)

Pilot fluid flows to the suspension valve (2) and control it. Pilot fluid discharge circuit consists of the valves (10), (11), (17), (18), (19), (20) and (22).

(When lifting the body)

When turning the solenoid (11) to **ON** position, the pilot fluid flows to the main spool (10) right side and slides the main spool (10) to the left side. Then, the fluid flows through the main spool (10) to suspension cylinder (16) extension side with opening the pilot check valve (13) so that the body is lifted.

(When descending the body)

When turning the solenoid (17) to **ON** position, the pilot fluid flows to the main spool (10) left side and slides the main spool (10) to the right side. Then, the fluid flows through the main spool (10) and the orifice to suspension cylinder (16) descent side so that the body is descended. The relief valve reduces the fluid pressure of the suspension cylinder descent side.

(When holding the body)

When turning off the solenoid for descending the body (17) and the solenoid for lifting the body (11), main fluid returns to the tank from the suspension valve. Cylinder fluid is kept all the time.

■ Cylinder Safety Device

1. When the shock is generated in the suspension cylinders (16), cylinder safety valve (23) functions to prevent damages to the suspension valve (2) and the suspension cylinder (16).
2. The pressure releasing valves (14), (25) and (26) return fluid from the circuit to the tank and prevent discharge of fluid during repairs.

■ Cylinder Lock System

The solenoid for lock cancellation (22) functions for releasing the suspension cylinder lock. ECU (FS) controls this solenoid (22). (Refer to "S9. ELECTRICAL SYSTEM" section.)

When turning the solenoid for releasing lock (23) to **OFF** position, the pilot fluid flow is blocked and the suspension cylinder (16) is locked surely.

When turning the solenoid for lock cancellation (22) to **ON** position, the pilot fluid flows to the double check valve (21) and opens it.

Then the cylinder extension side is connected to the accumulator (24) through the variable orifice (18), so that there is the series circuit between the accumulator (24) and the suspension cylinder (16).

■ Damping Force Controlling System

The variable orifice (18) controls the damping force with 3 positions, normal (holding), the middle damping force and the large damping force.

The variable orifice (18) is controlled by the solenoids (19), (20).

ECU (FS) controls the solenoids (19), (20). (Refer to "S9. ELECTRICAL SYSTEM" section.)

When turning the solenoid for middle damping force to **ON** position, the pilot fluid flows to the variable orifice (18) right side and slides the variable orifice (18) to the left side.

When turning the solenoid for large damping force to **ON** position, the pilot fluid flows to the variable orifice (18) left side and slides the variable orifice (18) to the right side.

■ Detection of Cylinder Pressure for ECU (FS)

Pressure sensor (15) detects the fluid pressure of the suspension cylinder extension side and sends output signals to ECU (FS). (Refer to "S9. ELECTRICAL SYSTEM" section.)

9Y1210525HYM0028US0

(3) Checking Fuse and Ground Wire



9Y1210447ELS002A

Fuses

1. Remove the left lower rear bonnet.
2. Check the fuses 5 A for circuit line (1) and 5 A for load line (2) related to power shift inside the fuse box and the fuse 5 A of the meter panel (3).
3. If any of the fuses is blown, replace it with the one having same capacity.

■ IMPORTANT

- If a fuse is blown, check the cause and be sure to replace it with the one having same capacity.

- (1) Fuse (5 A) Power Source for Circuit Line (3) Meter Panel Fuse (5 A)
- (2) Fuse (5 A) Power Source for Load Line

9Y1210525ELS0041US0

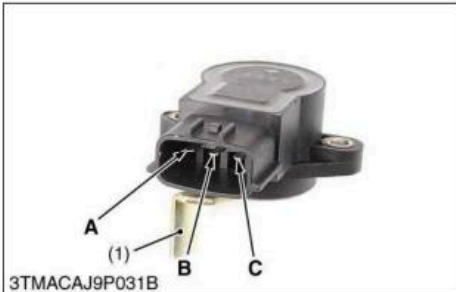

3TMACAJ9P031B

Power Shift/Range Shift Lever Sensor Resistance

1. Measure the resistance between terminal **A** and **C**.
2. Then, check resistance between terminal **A** and **B** while slowly turning the sensor lever (1).
3. It is OK if the resistance value is approximate to the value shown in the table below.

(Reference)

- The change of resistance can be checked easily when an analog tester is employed.

Resistance	Terminal A – Terminal C	1.6 to 2.4 kΩ
	Terminal A – Terminal B	Resistance is normal if smoothly changing

- (1) Sensor Lever

- A:** Terminal **A**
- B:** Terminal **B**
- C:** Terminal **C**

9Y1210525ELS0042US0



3TMACAJ9P035A

Shuttle Rotation Sensor

1. Remove the **CNT-A** connector (1).
2. Check the resistance between the terminal **A54** (Gy/B) and terminal **A56** (Gy/R) of the wire harness side.
3. Replace those of other than the standard value.

Item	Terminal No.	Wiring color	Resistance
Shuttle Rotation Sensor	A54 – A56	Gy/B - Gy/R	400 to 600 Ω

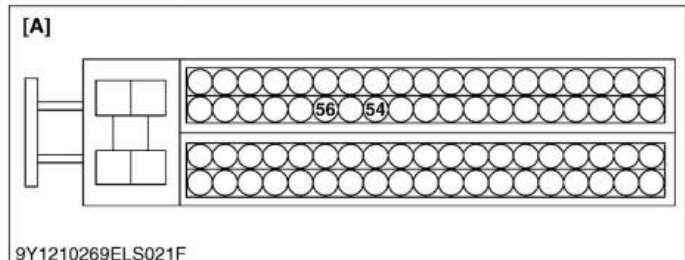

- (1) **CNT-A** Connector
- (2) Shuttle Rotation Sensor

[A] **CNT-A**

9Y1210525ELS0043US0

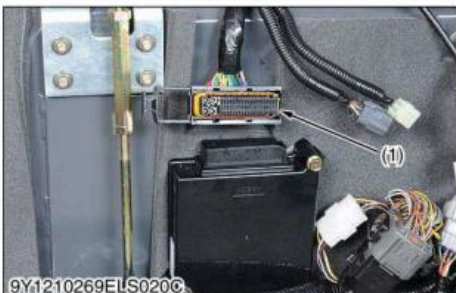

9Y1210269ELS020C

Full Version Available

Kubota M110X Tractor Workshop Manual

This is a short preview. The complete manual contains all chapters, wiring diagrams, torque specifications and full service procedures.

VIEW THE FULL MANUAL

<https://machinecatalogic.com/kubota-m110x-tractor-workshop-manual/>