

WSM

WORKSHOP MANUAL

TRACTOR

**M7132, M7152,
M7172, DeTier**

Kubota

18. Slide thrust washer (1) onto main shaft.

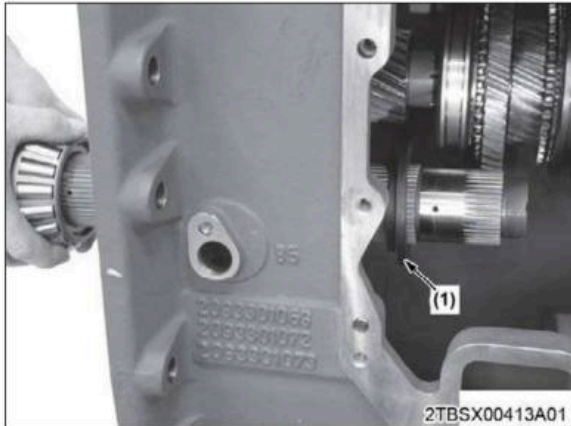

(1) Thrust washer

19. Lift assembled gears into transmission housing.

■ NOTE

- Conduct the following three work steps together.

20. Pull back main shaft as far as necessary.

21. Slide main shaft through gears.

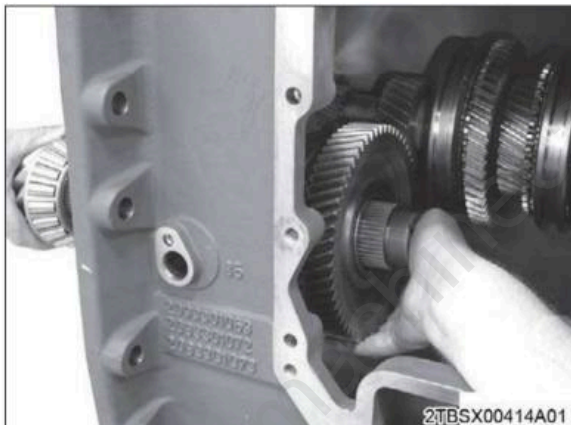

22. Lift helical gear into transmission housing.

■ NOTE

- Conduct the following two work steps together.

23. Slide main shaft through helical gear.

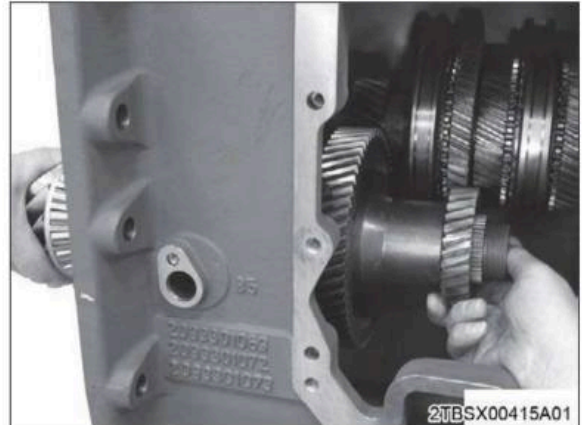

24. Lift double gear into transmission housing.

■ NOTE

- Conduct the following two work steps together.

25. Slide main shaft through double gear.

26. Slide main shaft into transmission housing until contact is obtained.

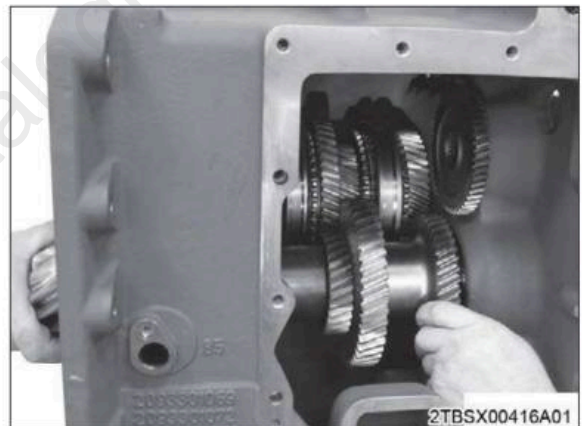

5. Remove the shaft bolts (3).
6. Push back the shaft and remove the spacer (4).

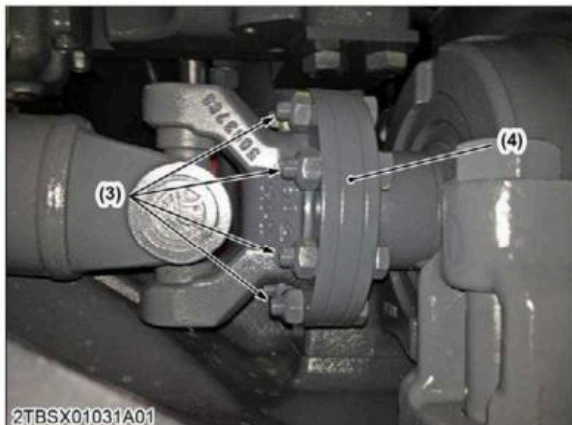

(3) Shaft bolt (4) Spacer

7. Attach a lifting belt to the front hook and hold it.



8. Tighten the relief pressure screw (5).

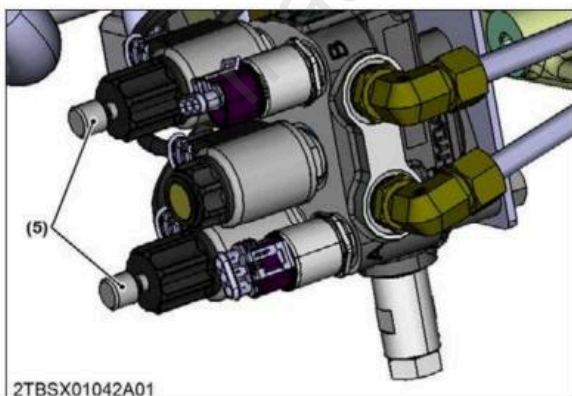

(5) Relief pressure screw

1.4.5.1 Removing front wheels

1. Mount the front axle assembly on rigid jacks.
2. Lift up the front wheels (1) and attach a wheel changer.
3. Remove the front wheels (1).



(1) Front wheel

(When reassembling)

- Tighten to the specified tightening torque.

Tightening torque	Front wheel bolts	540 N·m 55.1 kgf·m 390 lbf ft
-------------------	-------------------	-------------------------------------

1.4.5.2 Removing front 3-point hitch lock shift box and hoses

■ NOTE

- Shift the lever to LOCK position to minimize oil flow out.



(1) Front 3-point hitch lock shift box (2) Front 3-point hitch hose 1
(3) Front 3-point hitch hose 2

1. Remove the mount bolts of the front 3-point hitch lock shift box (1).
2. Remove the front 3-point hitch hose 1 (2) and 2 (3).

(When reassembling)

Tightening torque	Mounting bolt of front 3-point hitch lock shift box	23.5 to 27.5 N·m 2.40 to 2.80 kgf·m 17.4 to 20.2 lbf ft
-------------------	---	---

1.4.5.3 Removing hydraulic pipe

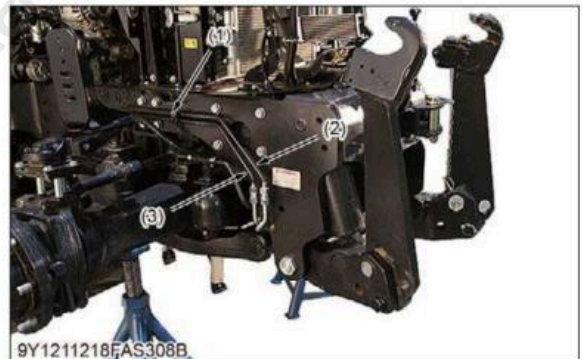

(1) Pipe clamp (2) Hydraulic pipe (3) Hydraulic pipe

1. Remove the pipe clamp (1).
2. Disconnect the hydraulic pipe (2) and hydraulic pipe (3) from the outlet port pipes.

4. (Reference) Check the signal status by K-OBD.

K-OBD item

xCU	Item	
VCU2 IO testing	PTO External Pushbutton	Right ON Pushbutton Value
		Right OFF Pushbutton Value

Reference value

Right ON Pushbutton Value Right OFF Pushbutton Value	Button pressed	Pressed
	Button released	Not pressed

5.13.34 Checking PST PTO rotation speed sensor (B15)

1. Disconnect the connector.

Location



Connector

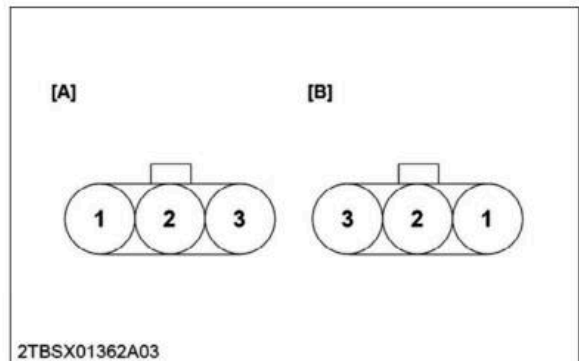

Related circuit

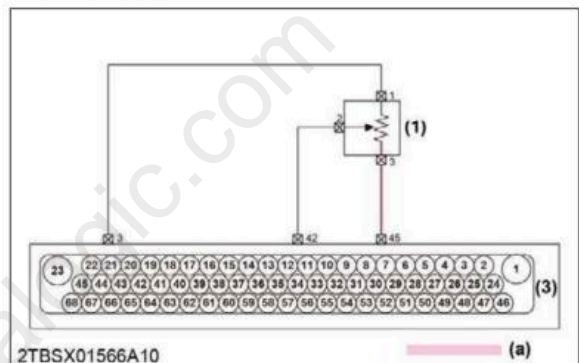

- (1) PTO rotation speed sensor (B15) [A] Connector (Harness side) [B] Connector (Sensor side)
- (2) PTO shaft detection sensor (B16) (a) Ignition line
- (3) TCU (XA82)

Pin	Color of wiring	Info
1	BR	GND
2	BR	Signal
3	V	Supply

2. Turn the main key switch to "ON" position.
3. Measure the voltage across the terminals (harness side) with a voltmeter.

Voltage	Terminal 3 - 1	Approx. 12 V
---------	----------------	--------------

4. Measure the resistance value between the terminals (sensor side) with an ohmmeter.
5. If the reference value is not as indicated, the valve is damaged.

2 - 1 at 1000 normal	Reference value	Engine 1995 min ⁻¹ (rpm): 333 Hz
----------------------	-----------------	---

Full Version Available

Kubota M7152 Tractor Workshop Manual

This is a short preview. The complete manual contains all chapters, wiring diagrams, torque specifications and full service procedures.

VIEW THE FULL MANUAL

<https://machinecatalogic.com/kubota-m7152-tractor-workshop-manual/>