

WSM

WORKSHOP MANUAL
TRACTOR

M6800, M8200, M9000

Кубота

[2] SEPARATING CLUTCH ASSEMBLING

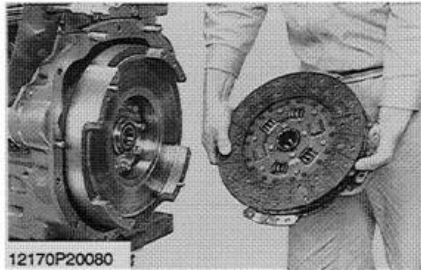

12170P20080

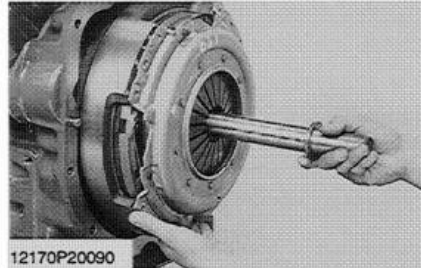

12170P20090

Separating the Clutch Assembling

1. Remove the clutch from the flywheel.

(When reassembling)

- Direct the shorter end of the clutch disc boss toward the flywheel.
- Apply molybdenum disulphide (Three Bond 1901 or equivalent) to the splines of clutch disc boss.
- Install the pressure plate, noting the position of straight pins.

IMPORTANT

- **Align the center of disc and flywheel by inserting the clutch center tool.**

NOTE

- **Do not allow grease and oil on the clutch disc facing.**

Tightening torque	Clutch mounting screw	23.5 to 27.5 N·m 2.4 to 2.8 kgf·m 17.4 to 20.3 ft·lbs
-------------------	-----------------------	---

12170S20150

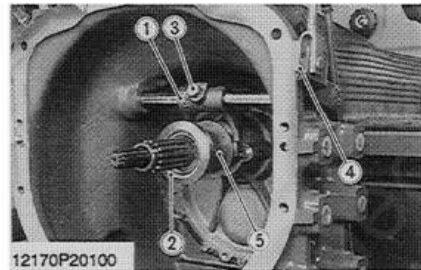

12170P20100

Release Holder and Clutch Lever

1. Draw out the clutch release holder (5) and the release bearing (2) as a unit.
2. Remove the release fork setting screws (3).
3. Draw out the clutch lever (4) to remove the release fork (1).

(When reassembling)

- Make sure the direction of the release fork (1) is correct.
- Apply grease to the release holder (5) and on the shaft.
- Apply grease to the bushing and clutch lever.
- After tightening the release fork setting screw to the specified torque, insert a wire through the hole on the setting screw head and bind with release fork together.

Tightening torque	Release fork setting screw	166.7 to 186.3 N·m 17.0 to 19.0 kgf·m 123.0 to 137.4 ft·lbs
-------------------	----------------------------	---

- | | |
|---------------------|--------------------|
| (1) Release Fork | (4) Clutch Lever |
| (2) Release Bearing | (5) Release Holder |
| (3) Setting Screw | |

12170S20160

SERVICING



11790P20370

Clearance between Clutch Pedal Shaft and Pedal Bushing

1. Measure the clutch pedal shaft O.D. with an outside micrometer.
2. Measure the clutch pedal bushing I.D. with a cylinder gauge.
3. Calculate the clearance.
4. If the clearance exceeds the allowable limit, replace the bushing.

Clearance between clutch pedal shaft and pedal bushing	Factory spec.	0.025 to 0.185 mm 0.00098 to 0.00728 in.
	Allowable limit	1.00 mm 0.0394 in.

12170S20030

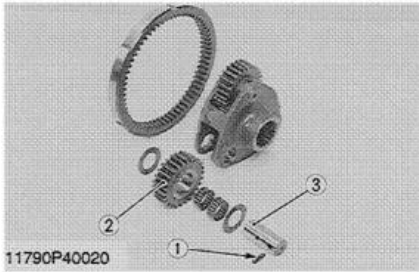

Planetary Gear

1. Tap the spring pin (1) into the planetary gear shaft (3).
2. Draw out the planetary gear shaft (3), and remove the planetary gear (2).
3. Tap out the spring pin from the planetary gear shaft.

(When reassembling)

- Apply transmission fluid to the inner surface of planetary gear (2).
- Tap in the spring pin (1) as shown in the figure.

- (1) Spring Pin (3) Planetary Gear Shaft
 (2) Planetary Gear

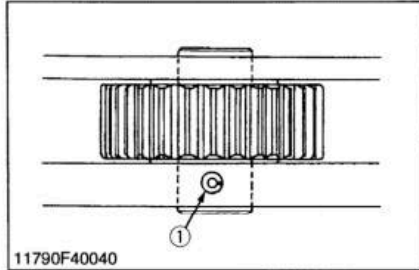

11790S40050

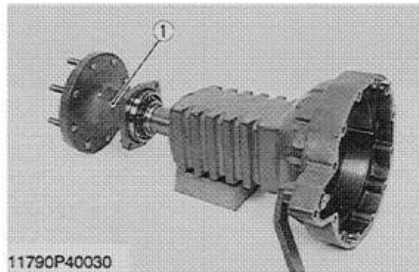

Rear Axle

1. Unscrew the rear axle cover mounting screws, and remove the rear axle (1).

(When reassembling)

Tightening torque	Rear axle cover mounting screw	77.5 to 90.2 N·m 7.9 to 9.2 kgf·m 57.1 to 66.5 ft·lbs
-------------------	--------------------------------	---

- (1) Rear Axle

11790S40060

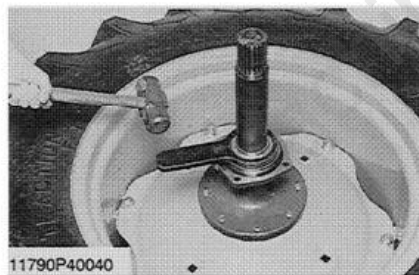

Rear Axle Nut

1. Fix the rear axle on the repair table or set to the rear wheel.
2. Remove the stake on the rear axle nut.
3. Remove the rear axle nut with a rear axle nut wrench 85 (Code No. 07916-52541).

(When reassembling)

- Replace the rear axle nut with a new one, and stake if firmly after tightening.

Tightening torque	Rear axle nut	539.4 to 637.5 N·m 55 to 65 kgf·m 397.8 to 470.1 ft·lbs
-------------------	---------------	---

12170S40130

■ Right Turning

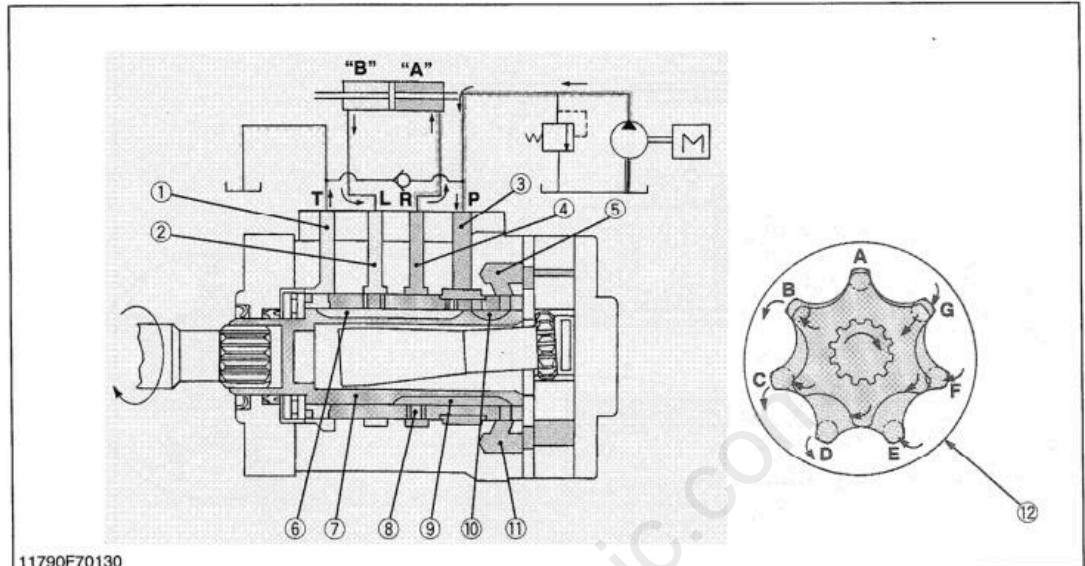

11790F70130

(1) Passage
(2) Passage
(3) Passage

(4) Passage
(5) Passage
(6) Spool Groove

(7) Spool
(8) Sleeve
(9) Passage

(10) Spool Groove
(11) Passage
(12) Gerotor

1. When the operator attempts to turn the steering wheel clockwise, only the spool (7) is rotated a small amount overcoming the force of the centering spring, thereby causing a relative displacement between the spool (7) and the sleeve (8). As a result, while the passage from the passage (3) to the spool groove (6) is throttled, the passage from (3) to (1) and (5) is opened, forming a passage to the three pump chambers E, F and G (in sucking-in state) of the gerotor. At the same time, a passage is formed from the three chambers B, C and D (in oil discharging state) of the gerotor to the cylinder port R through the passages (11), (9) and (4).
2. Oil pressure generated at this time in the three chambers E, F and G of the gerotor, that is oil pressure generated in the spool groove (10), is set depending on the extent of throttling from (3) to (6). The extent of throttling increases as the relative displacement between the spool (7) and the sleeve (8) increases. Accordingly, at small relative displacements, oil pressure generated in the three chambers E, F and G of the gerotor is too low to move the piston overcoming road resistance. When

the relative displacement increases to such an extent that oil pressure generated in the three chambers E, F and G rises up to the operating pressure, the rotor rotates and oil in the three chambers B, C and D of the gerotor which are in the discharging state is pressure-fed to the cylinder chamber "A" to steer. On the other hand, oil discharged from the cylinder chamber "B" returns to the oil tank from tank port T, after following through the passages (2), (6) and (1) from the cylinder port L.

3. When the steering wheel is turned, a relative displacement develops and generates operating pressure corresponding to the road resistance, and the spool (7) and sleeve (8) rotate as the steering wheel is turned. As already described, the gerotor serves as a metering device so that the wheels are turned to the angle corresponding to the turn of the steering wheel.
4. When the steering wheel is stopped, a relative displacement between the spool (7) and the sleeve (8) becomes zero due to the function of the centering spring, and the neutral state is restored.

11790M70100

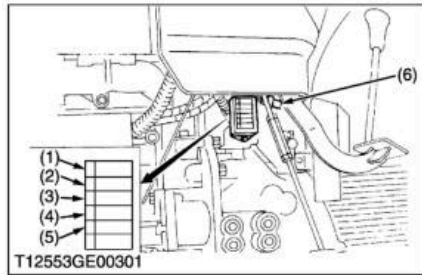

Replacing Fuse

1. The tractor electrical system is protected from potential damage by fuses.
A blown fuse indicates that there is an overload or short somewhere in the electrical system.
2. If any of the fuses should blow, replace with a new one of the same capacity.

■ IMPORTANT

- Before replacing a blown fuse, determine why the fuse blew and make any necessary repairs. Failure to follow this procedure may result in serious damage to the tractor electrical system. Refer to troubleshooting section of this manual or your local KUBOTA dealer for specific information dealing electrical problems.

M5700HD

FUSE No.	CAPACITY (A)	Protected circuit
(1)	15	Main key
(2)	15	Head light. Flasher
(3)	10	Parking. Hazard
(4)	10	Work Light
(5)	15	Key stop
(6)	50 Slow blow fuse	Check circuit against wrong battery connection

M6800HD

FUSE No.	CAPACITY (A)	Protected circuit
(1)	20	Main key
(2)	15	Head light
(3)	10	Parking · Flasher (Hazard)
(4)	10	Work Light
(6)	50 Slow blow fuse	Check circuit against wrong battery connection

W1019843

Full Version Available

Kubota M8200 Tractor Workshop Manual

This is a short preview. The complete manual contains all chapters, wiring diagrams, torque specifications and full service procedures.

VIEW THE FULL MANUAL

<https://machinecatalogic.com/kubota-m8200-tractor-workshop-manual/>