

# WSM

---

WORKSHOP MANUAL  
**TRACTOR**

**M8200DNB(SUPPLEMENT),  
M8200SDNB, M8200SDNBC**

---

**Кубота**

**(B) Shuttle Shift Section**

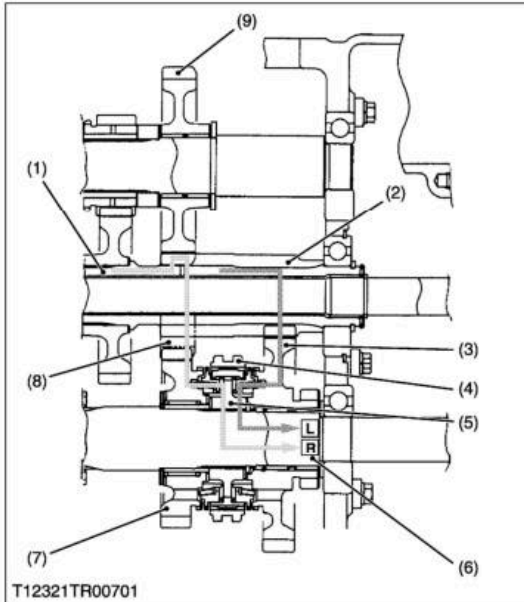

**■ Lo-Reverse Synchro Shuttle**

The shuttle shift section allows the operators to change forward and reverse with an auxiliary speed change lever. It is used synchromesh type gear shift.

It also operates as a reduction until when shifting from forward to reverse.

When the auxiliary speed change lever is move to the L or R position, the shifter (4) is slide to the rear or front by the mechanical linkage to be engaged with the 32T (7) or 41T gear (3).

Then, the power is transmitted to the 3rd shaft (6).

The power is transmitted as follows.

**■ Lo (Forward)**

2nd Shaft (1) → 13T Gear (2) → 41T Gear (3) → Shifter (4) → Hub (5) → 3rd Shaft (6).

**■ Reverse**

2nd Shaft (1) → 13T Gear (2) → 35T Gear (9) → 13T Gear (8) → 32T Gear (7) → Shifter (4) → Hub (5) → 3rd Shaft (6).

- |               |               |
|---------------|---------------|
| (1) 2nd Shaft | (6) 3rd Shaft |
| (2) 13T Gear  | (7) 32T Gear  |
| (3) 41T Gear  | (8) 13T Gear  |
| (4) Shifter   | (9) 35T Gear  |
| (5) Hub       |               |

W1016053

**(C) Hi-Creep Shift Section**

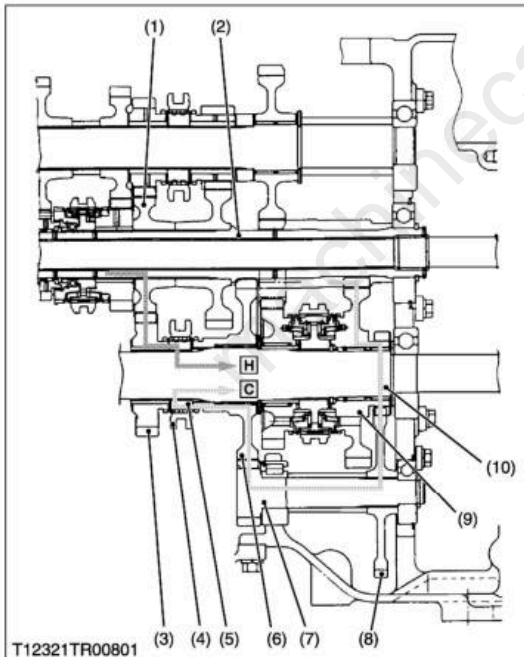

**■ Hi-Creep Shift**

The Hi-Creep shift section allows the operator to change Hi and Creep with an auxiliary speed change lever.

When the auxiliary speed change lever is move to the Hi or Creep position, the shifter (4) is slide to the front or rear by mechanical linkage to be engaged with the 21T gear (3) or 47T gear (6).

The power is transmitted as follows.

**■ Hi-Range**

2nd Shaft (2) → 24T Gear (1) → 21T Gear (3) → Shifter (4) → Hub (5) → 3rd Shaft (10).

**■ Creep Range**

2nd Shaft (2) → 41T-19T Gear (9) → 43T Gear (8) → 15T Gear Shaft (7) → 47T Gear (6) → Shifter (4) → Hub (5) → 3rd Shaft (10).

- |               |                    |
|---------------|--------------------|
| (1) 24T Gear  | (6) 47T Gear       |
| (2) 2nd shaft | (7) 15T Gear Shaft |
| (3) 21T Gear  | (8) 43T Gear       |
| (4) Shifter   | (9) 41T-19T Gear   |
| (5) Hub       | (10) 3rd Shaft     |

W1016689

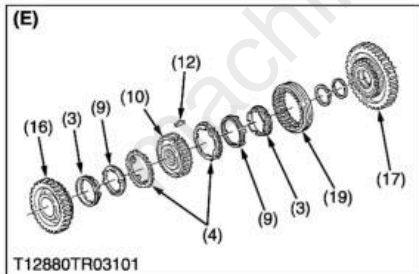
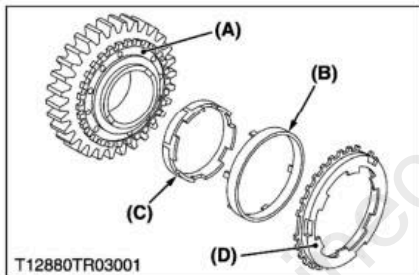
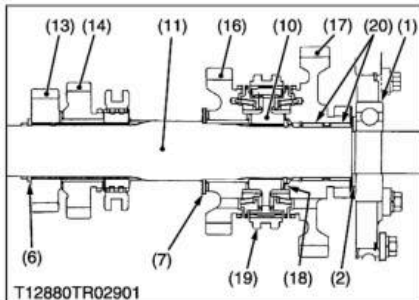
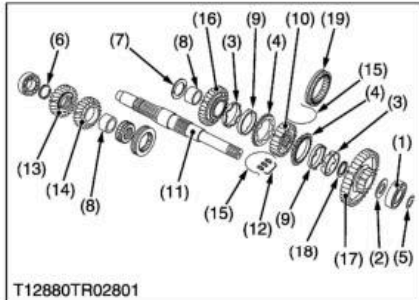

**3rd Shaft**

1. Tap out the 3rd shaft with gears to the front.

**(When reassembling)**

- Apply enough transmission fluid to the synchronizer portion, needle bearings (20) and thrust collars (2) and (7).
- Direct the grooved side of the thrust collar (2) to the needle bearing (20) side.
- Install the protrusion portions **(B)** of the center rings (9) to the holes **(A)** of the gear (16) and (17) firmly. (Refer to the figure left.)
- Install the protrusion portion **(D)** of the outer synchronizer rings (4) to the grooves **(C)** of the inner synchronizer rings (3). (Refer to the figure left.)
- Install the external snap ring (18) to the groove of the 3rd shaft (11) firmly.
- Install the synchronizer keys (12) in the key grooves of the outer synchronizer rings (4) firmly.
- Apply molybdenum disulfide (Three Bond 1901 or equivalent) to inner of 24T gear (14), 32T gear (16).

- |                              |                         |
|------------------------------|-------------------------|
| (1) Bearing                  | (16) 32T Gear           |
| (2) Thrust Collar            | (17) 41T Gear           |
| (3) Inner Synchronizer Ring  | (18) External Snap Ring |
| (4) Outer Synchronizer Ring  | (19) Shifter            |
| (5) External Snap Ring       | (20) Needle Bearing     |
| (6) External Snap Ring       |                         |
| (7) Thrust Collar            |                         |
| (8) Inner Ring               |                         |
| (9) Center Ring              |                         |
| (10) Hub                     |                         |
| (11) 3rd Shaft               |                         |
| (12) Synchronizer Key        |                         |
| (13) 26T Gear                |                         |
| (14) 24T Gear                |                         |
| (15) Synchronizer Key Spring |                         |

- (A) Holes of the gear**
- (B) Protrusion portions of the center ring**
- (C) Grooves of the inner synchronizer ring**
- (D) Protrusion portion of the outer synchronizer ring**
- (E) Double Cone Type Synchronmesh**

W1016870

**(4) Checking and Adjusting**

**Toe-in**

1. See page 6-S6.

W1011597

**Axial Sway of Front Wheel**

1. See page 6-S6.

W1011643

**Adjusting Front Axle Pivot**

1. See page 6-S7.

W1011688

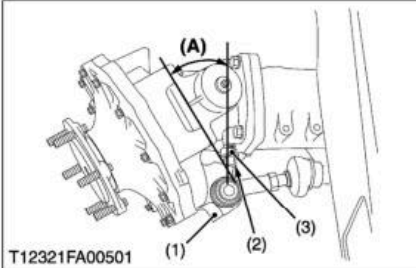

**Front Wheel Steering Angle**

1. Inflate the tires to the specified pressure.
2. Steer the wheels to the extreme left until the front gear case (1) contacts with the stopper bolt (2) at right hand side of the front axle and measure the steering angle (A).
3. If the steering angle is not within the factory specifications, be sure to adjust it by changing the number of the adjusting washers (3).

Steering angle (A) between front gear case and stopper bolt	Factory spec.	0.593 to 0.628 rad. 34 to 36 °
---	---------------	-----------------------------------

- (1) Front Gear Case
- (2) Stopper Bolt
- (3) Adjusting Washer

(A) Steering Angle

W1011882

**(5) Disassembling and Assembling**

**(A) Separating Front Axle**

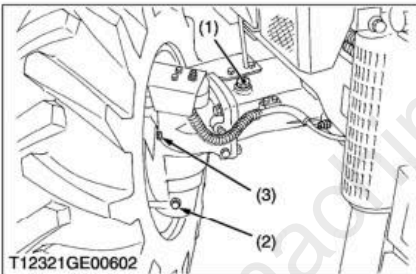

**Draining Front Axle Case Oil**

1. Place oil pans underneath the front wheel case.
2. Remove the drain plug (2) and filling plug (1) to drain the oil.
3. After draining, reinstall the drain plug (2) and filling plug (1).

Oil capacity	6.0 L 6.3 U.S.qts. 5.3 Imp.qts.
--------------	---------------------------------------

- (1) Filling Plug
- (2) Drain Plug

(3) Breather Plug

W1012114

machinecatalogic.com

**CABIN**

# Full Version Available

Kubota M8200SDNBC Tractor Workshop Manual  
(Supplement)

This is a short preview. The complete manual contains all chapters, wiring diagrams, torque specifications and full service procedures.

[VIEW THE FULL MANUAL](#)