

# WSM

---

WORKSHOP MANUAL

F2890, F3690, RCK60P-F39,  
RCK60R-F36, RCK72P-F39,  
RCK72R-F36

---

**Kubota**

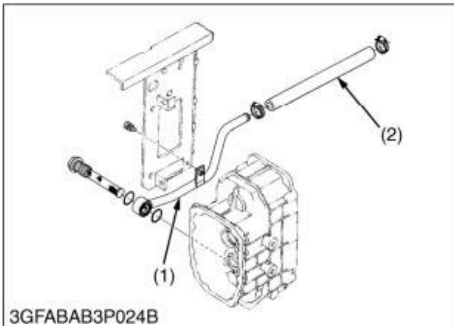

### Suction Hose and Suction Pipe

1. Disconnect the suction hose (2) from front suction pipe (1).
2. Remove the rear suction pipe (3) and suction hose (2) together.

#### (When reassembling)

- Apply grease to O-ring and be careful not to damage it.

- (1) Front Suction Pipe  
(2) Suction Hose

- (3) Rear Suction Pipe

9Y1210917ENS0029US0

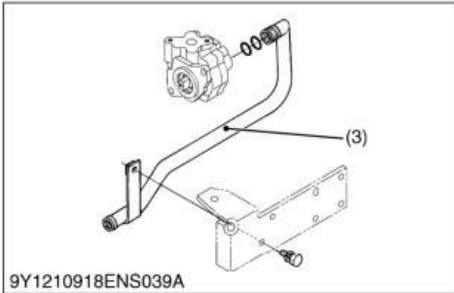

### Drive Shaft

1. Remove the drive shaft mounting screws (2), and disconnect the drive shaft (3) from the fan drive pulley (1).

#### (When reassembling)

- Apply grease to the all splines on the drive shaft.

Tightening torque	Drive shaft mounting screw	20 to 29 N·m 2.0 to 3.0 kgf·m 15 to 21 lbf·ft
-------------------	----------------------------	---

- (1) Fan Drive Pulley  
(2) Drive Shaft Mounting Screws

- (3) Drive Shaft

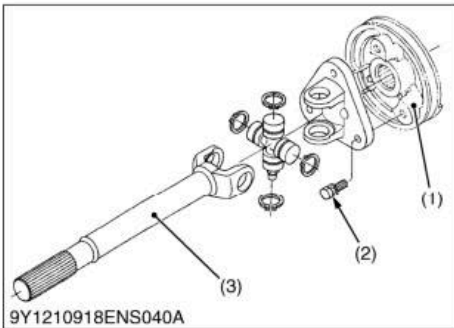

9Y1210917ENS0030US0

## 6. DIFFERENTIAL GEAR SECTION

### [1] DIFFERENTIAL FUNCTION

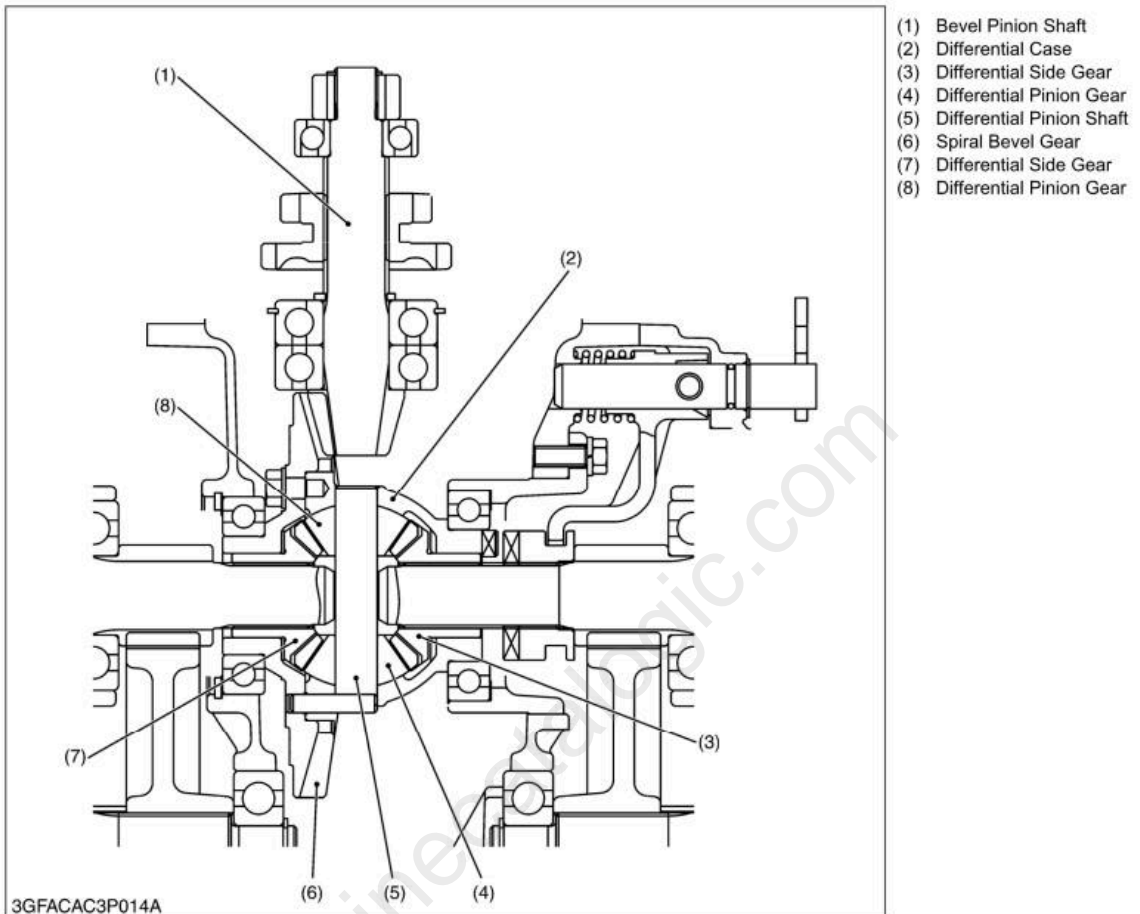

- (1) Bevel Pinion Shaft
- (2) Differential Case
- (3) Differential Side Gear
- (4) Differential Pinion Gear
- (5) Differential Pinion Shaft
- (6) Spiral Bevel Gear
- (7) Differential Side Gear
- (8) Differential Pinion Gear

#### 1. During Straight Running

Rotation of the bevel pinion shaft (1) is transmitted to the spiral bevel gear (6) and differential case (2).

When road resistance to the right and left wheels are equal, differential pinions (4), (8) and differential side gears (3), (7) all turn as a unit. Both front axles received equal input, and both wheels turn at the same speed, allowing the machine to go straight ahead.

At this time, differential pinions (4), (8) do not rotate around the differential pinion shaft (5).

#### 2. During Turning

When the machine turns, the road resistance to the inside tire increases (as if braking is applied to that side only). In other words, if one of tires slows down, revolution difference is generated in the differential side gears (3), (7). When rotation of one differential side gear becomes lower than the other, differential pinions (4), (8) begin rotating around differential pinion shaft (5). The other differential side gear is increased in speed by the speed increment of differential pinion shaft (5). This means that rotation of one front axle is slowed down and that of the other front axle is increased. Thus, the machine turns smoothly without power loss.

The combined number of revolutions of the right and left differential side gears (3), (7) is always twice that of the spiral bevel gear (6). When spiral bevel gear revolution is  $100 \text{ min}^{-1}$  (rpm), and if one of the differential side gears stops moving, the revolution of the other differential side gear becomes  $200 \text{ min}^{-1}$  (rpm) and if one rotates at  $50 \text{ min}^{-1}$  (rpm), the other rotates at  $150 \text{ min}^{-1}$  (rpm)

9Y1210917TRM0022US0

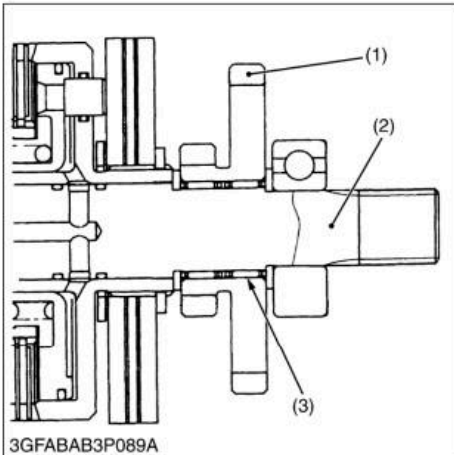

**Clearance between Clutch Shaft and 16T-33T Gear**

1. Measure 16T-33T gear I.D. with an inside micrometer, and then the clutch shaft O.D. with an outside micrometer.
2. Measure O.D. of two needles in the needle bearing with an outside micrometer.
3. Clearance is the difference between the gear I.D. and the sum of shaft O.D. and two needle O.D..
4. If the clearance exceeds the allowable limit, replace it.

Clearance between clutch shaft and 16T-33T gear	Factory specification	0.007 to 0.047 mm 0.0003 to 0.0018 in.
	Allowable limit	0.10 mm 0.0039 in.

16T-33T gear I.D.	Factory specification	26.007 to 26.028 mm 1.0239 to 1.0247 in.
-------------------	-----------------------	---

Clutch shaft O.D.	Factory specification	21.987 to 22.000 mm 0.8657 to 0.8661 in.
-------------------	-----------------------	---

Needle O.D.	Factory specification	1.997 to 2.000 mm 0.0786 to 0.0787 in.
-------------	-----------------------	---

- (1) 16T-33T Gear  
(2) Clutch Shaft

- (3) Needle Bearing

9Y1210917TRS0064US0

**(3) Transmission Case**

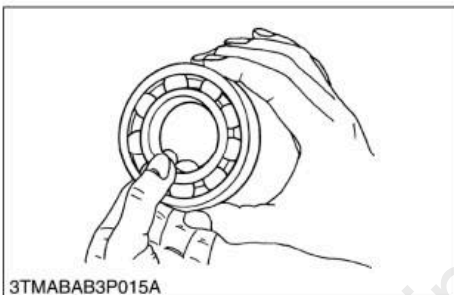

**Checking Bearing**

1. While holding the inner race, push and pull the outer race in all directions to check for wear and roughness.
2. Apply transmission oil to the bearing, and hold the inner race. Then, turn the outer race to check rotation.
3. For needle bearing, invert the needle rollers to check for any damage and wear.
4. If problems are found, replace it.

9Y1210917TRS0065US0

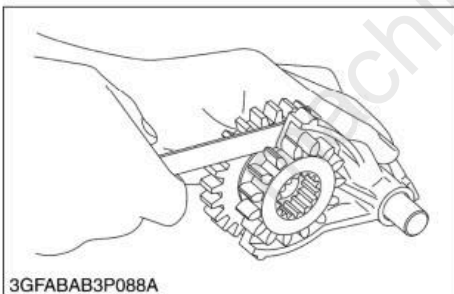

**Clearance between Shift Fork and 15T-26T Gear Groove**

1. Insert the shift fork into the 15T-26T gear groove, and measure the clearance with a feeler gauge.
2. If the clearance exceeds the allowable limit, replace it.

Clearance between shift fork and 15T-26T gear	Factory specification	0.03 to 0.40 mm 0.0001 to 0.015 in.
	Allowable limit	0.5 mm 0.020 in.

9Y1210917TRS0066US0

**Stopping the Engine, Automatically**

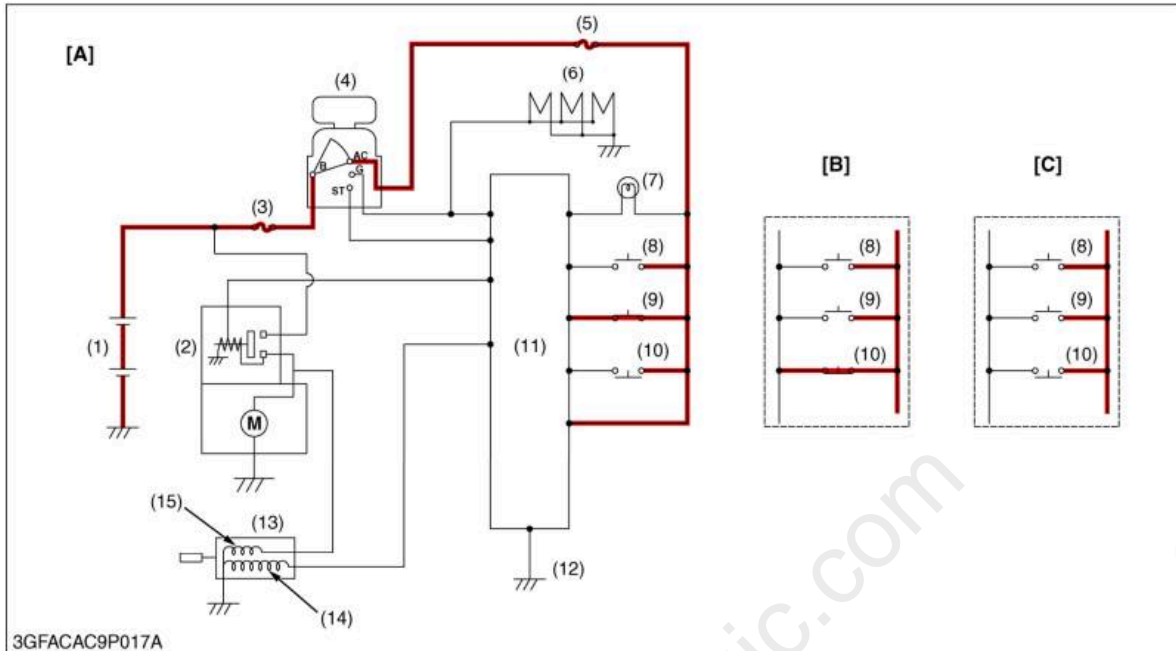

- (1) Battery
- (2) Starter
- (3) Slow Blow Fuse (50 A)
- (4) Main Switch
- (5) Fuse (5 A)
- (6) Seat Switch
- (7) PTO Switch
- (8) Brake Switch
- (9) OPC Controller
- (10) Frame Earth
- (11) Engine Stop Solenoid
- (12) Holding Coil
- (13) Pulling-in Coil

- [A] Condition 1
- [B] Condition 2
- [C] Condition 3

When the following conditions become complete, the electrical current does not flow to the holding coil (12) of the engine stop solenoid (11) from the controller (9). Then, the engine will stop in 0.6 to 1.4 seconds.

Condition	Seat Switch (6) (Occupied: <b>ON</b> ) (Vacant: <b>OFF</b> )	PTO Switch (7) (Disengaged: <b>ON</b> ) (Engaged: <b>OFF</b> )	Brake Switch (8) (Pedal depressed: <b>ON</b> ) (Pedal free: <b>OFF</b> )
1	OFF	ON	OFF
2	OFF	OFF	ON
3	OFF	OFF	OFF

9Y1210917ELM0008US0

# Full Version Available

Kubota RCK60P-F39 Rotary Mower Workshop Manual

This is a short preview. The complete manual contains all chapters, wiring diagrams, torque specifications and full service procedures.

[VIEW THE FULL MANUAL](#)