

TO THE READER

This Workshop Manual has been prepared to provide servicing personnel with information on the mechanism, service and maintenance of KUBOTA Lawn Tractors T1400 and T1400H. It is divided into two parts, "Mechanism" and "Disassembling and Servicing".

■ Mechanism

Information on the construction and function of each lawn tractor are included in this section. This part should be understood before proceeding with troubleshooting, disassembling and servicing.

■ Disassembling and Servicing

The heading "General" includes general precautions, troubleshooting, servicing specification lists, check and maintenance and special tools. For each lawn tractor section, there are checking and adjusting, disassembling and assembling, and servicing which cover procedures, precautions, factory specifications and allowable limits.

All information, illustrations and specifications contained in this manual are based on the latest production information available at the time of publication.

KUBOTA reserves the right to make changes in information at any time without notice.

July '87

© KUBOTA, LTD. 1987

ENGINE BODY (Continued)

Item		Factory Specification	Allowable Limit
Connecting Rod on Crank Pin	Side Clearance	0.4 to 1.1 mm 0.016 to 0.043 in.	1.5 mm 0.059 in.
Crankshaft	Side Clearance	—	0.1 mm 0.004 in.
Cam (Intake and Exhaust)	Height	34.685 to 34.715 mm 1.36555 to 1.36673 in.	34.5 mm 1.358 in.

LUBRICATING SYSTEM

Engine Oil Pressure	At Idling	20 kPa or more 0.2 kgf/cm ² or more 3 psi or more	—
	At maximum speed (3350 rpm)	98 kPa or more 1.0 kgf/cm ² or more 14 psi or more	29 kPa 0.3 kgf/cm ² 4 psi
Rotor lobe	Clearance	0.15 mm or less 0.0059 in. or less	0.20 mm 0.0079 in.
Outer Rotor to Pump Body	Clearance	0.130 to 0.223 mm 0.0051 to 0.0088 in.	0.25 mm 0.0098 in.
Rotor and Cover	Clearance	0.02 to 0.06 mm 0.0008 to 0.0024 in.	0.25 mm 0.0098 in.

IGNITION SYSTEM

Spark Plug	Gap	0.9 to 1.0 mm 0.035 to 0.039 in.	—
Ignition Unit Core to Rotor Magnet	Clearance	0.5 mm 0.020 in.	—
Coil Test (Simplified Test with Ohmmeter)	Primary coil	Resistance	Approx. 1 Ω
	Secondary coil	Resistance	Approx. 9.5 kΩ

TRANSMISSION AND REAR AXLE

Maximum Forward Speed (T1400H)		104 to 120 rpm (Tire size: 18 x 8.50-8)	—
Maximum Reverse Speed (T1400H)		49 to 67 rpm (Tire size: 18 x 8.50-8)	—
12T Bevel Pinion Shaft to 27T Bevel Gear (T1400H)	Backlash	0.1 to 0.3 mm 0.004 to 0.012 in.	0.4 mm 0.016 in.
Maximum Speed (T1400)		98 to 116 rpm (Tire size: 18 x 8.50-8)	—

(2) Carburetor and Governor

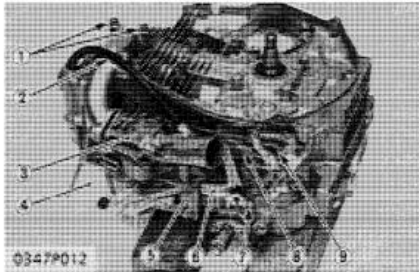

Carburetor and Governor Lever

1. Remove the breather pipe (2).
2. Remove the governor spring (8).
3. Loosen the choke rod retaining screw (9).
4. Remove the air cleaner elbow stay (5).
5. Unscrew the intake elbow mounting screws (1).
6. Loosen the governor lever mounting screw (7), and remove the carburetor (3) with the governor lever (6).
7. Remove the cover (4).

(When reassembling)

- Pushing the throttle valve to the fully open position with the governor lever (6), turn the governor lever shaft (10) clockwise (governor fully closed position) with a screwdriver and tighten the governor lever mounting screw (7) in that position.

Tightening torque	Governor lever mounting screw	17.7 to 23.5 N·m 1.8 to 2.4 kgf·m 13.0 to 17.4 ft·lbf
-------------------	-------------------------------	---

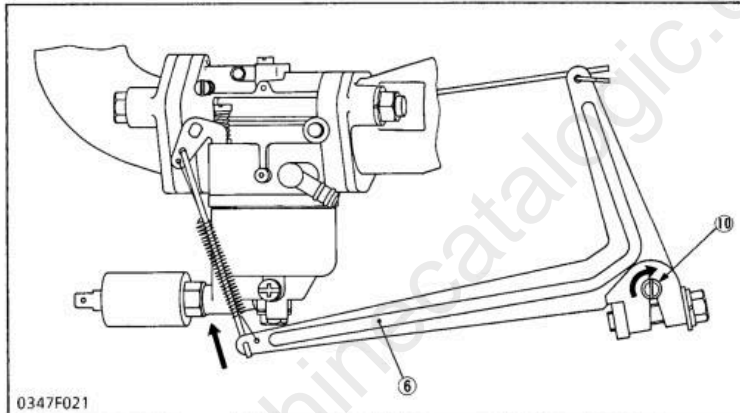

- (1) Intake Elbow Mounting Screw
- (2) Breather Pipe
- (3) Carburetor
- (4) Cover
- (5) Air Cleaner Elbow Stay
- (6) Governor Lever
- (7) Governor Lever Mounting Screw
- (8) Governor Spring
- (9) Choke Rod Retaining Screw
- (10) Governor Lever Shaft

0347F021

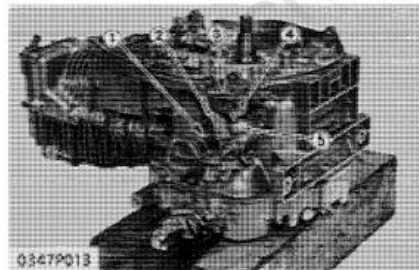

Speed Control Lever and Speed Control Plate

1. Remove the spring (3) and return spring (1).
2. Unscrew the speed control lever mounting nut, and remove the speed control lever 1 (2) and 2 (4).
3. Unscrew the speed control plate mounting screw, and remove the speed control plate (5).

- | | |
|---------------------------|---------------------------|
| (1) Return Spring | (4) Speed Control Lever 2 |
| (2) Speed Control Lever 1 | (5) Speed Control Plate |
| (3) Spring | |

0347P013

[3] LUBRICATING SYSTEM

DISASSEMBLING AND ASSEMBLING

(1) Oil Pump

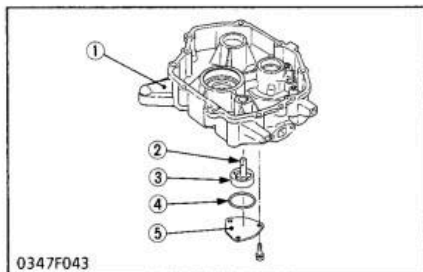

- (1) Crankcase Cover (4) O-ring
 (2) Inner Rotor (5) Oil Pump Cover
 (3) Outer Rotor

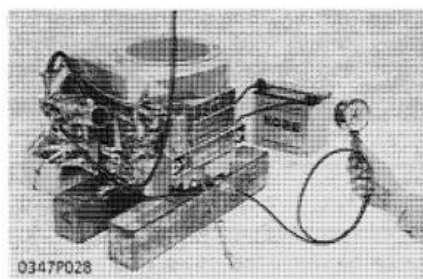

Oil Pump

1. Unscrew the screws retaining the oil pump cover (5).
2. Push out the inner rotor (2) from inside of the crankcase cover (1) after removing crankcase cover.
3. Remove the outer rotor (3).

(When reassembling)

- Apply engine oil to each section.

NOTE

- Be sure to fit the inner rotor into the end groove of balancer shaft 1.
- After assembling the oil pump, be sure to check the engine oil pressure.

Checking Oil Pressure

1. Unscrew the plug, and install the engine oil pressure tester (Code No. 07916-32031). (Adaptor screw size: PT 1/8)
2. Start the engine. After warming up, measure the oil pressure of both idling and maximum speeds.
3. If the oil pressure is less than the allowable limit, check the following.

- Engine oil insufficient
- Oil pump defective
- Oil strainer clogged
- Oil gallery clogged
- Excessive oil clearance between crank pin and connecting rod big end
- Relief valve defective

Engine oil pressure	At idling	Factory spec.	20 kPa or more 0.2 kgf/cm ² or more 3 psi or more
	At maximum speed (3350 rpm)	Factory spec.	98 kPa or more 1.0 kgf/cm ² or more 14 psi or more
		Allowable limit	29 kPa 0.3 kgf/cm ² 4 psi

(When reassembling)

- After checking the engine oil pressure, tighten the plug to the specified torque.

Tightening torque	Plug	9.8 to 15.7 N·m 1.0 to 1.6 kgf·m 7.2 to 11.6 ft·lbs
-------------------	------	---

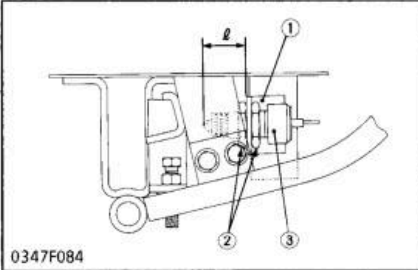

0347F084

Safety Switch Setting Length

1. Measure the length (ℓ) between the safety switch mounting plate (1) and the tip of safety switch (3).
2. If the measurement is not within the factory specifications, adjust with the safety switch mounting nuts (2).

Length (ℓ) between safety switch mounting plate and tip of safety switch	Factory spec.	34 to 35 mm 1.34 to 1.38 in.
---	---------------	---------------------------------

NOTE

- Install the safety switch mounting plate (1) as shown in the figure.

- (1) Safety Switch Mounting Plate (3) Safety Switch
(2) Safety Switch Mounting Nut

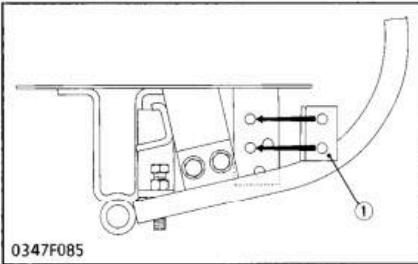

0347F085

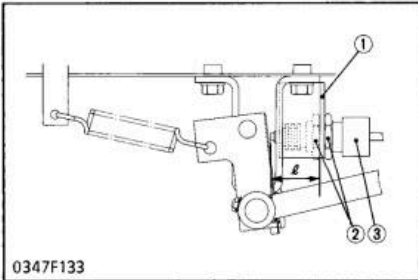

0347F133

Safety Switch Setting Length

[Lawn Tractor Serial Number: 30001 and beyond]

1. Measure the length (ℓ) between the safety switch mounting plate (1) and the tip of safety switch (3).
2. If the measurement is not within the factory specifications, adjust with the safety switch mounting nuts (2).

Length (ℓ) between safety switch mounting plate and tip of safety switch	Factory spec.	34 to 35 mm 1.34 to 1.38 in.
---	---------------	---------------------------------

- (1) Safety Switch Mounting Plate (3) Safety Switch
(2) Safety Switch Mounting Nut

(2) T1400-Type

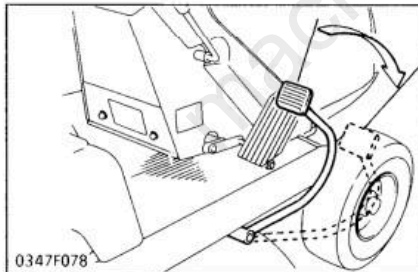

0347F078

Clutch-Brake Pedal Travel

1. Measure the clutch-brake pedal travel from the free position to the end by pushing the pedal.
2. If it is not within the factory specifications, turn the adjusting screw (1) to adjust.

Clutch-brake pedal travel	Factory spec.	125 to 130 mm 4.92 to 5.12 in.
---------------------------	---------------	-----------------------------------

Full Version Available

Kubota T1400H Lawn Tractor Workshop Manual

This is a short preview. The complete manual contains all chapters, wiring diagrams, torque specifications and full service procedures.

VIEW THE FULL MANUAL

<https://machinecatalogic.com/kubota-t1400h-lawn-tractor-workshop-manual/>