

WSM

WORKSHOP MANUAL

T1570, T1670, T1770, T1870

Kubota



Case 6: Stem Corrosion

1. Moisture in fuel or from condensation are the most common causes of valve stem corrosion.
2. Condensation occurs from improper preservation during storage and when engine is repeatedly stopped before it has a chance to reach normal operating temperatures.
3. Replace corroded valves.

W1035571



Case 7: Gum

1. Gum deposits usually result from using state gasoline. This condition is often noted in applications where fuel is not drained out of tank during the off season. Gum is a prevalent cause of valve sticking. The cure is to ream the valve guides and clean or replace the valves, depending on their condition.

W1035642



Case 8: Overheating

1. An exhaust valve subject to overheating will have a dark discoloration in the area above the valve guide. Worn guides and faulty valve springs may cause this condition. Also check for clogged air intake, and blocked fins when this condition is noted.

W1035752

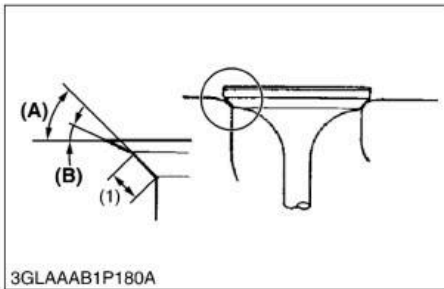

3GLAAB1P180A

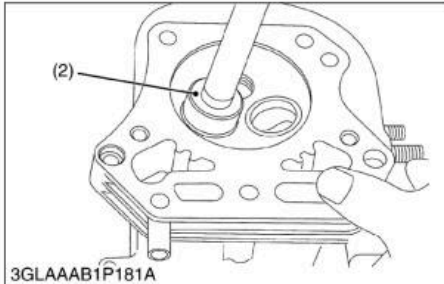

3GLAAB1P181A

Operating Procedures:

1. Clean the seat area carefully.
2. Recondition the valve seats with the valve seat cutters (45°, 30°) and lap the valve.
3. Check the seats for good contact all the way around with machinist's dye.
4. Measure the seat width (1). If it is more than the STD width, the seating surface should be refaced.
5. If the valve seating pattern is not correct, repair the seat.
6. Coat the seat with machinist's dye.
7. Fit a 45° cutter (2) to the holder and slide it into the valve guide. Resurface the valve seat with a 45° cutter, removing only enough material to produce a smooth and concentric seat.

⚠ CAUTION

- Do not grind the seat too much. Overgrinding will reduce valve clearance by sinking the valve into the head. If the valve sinks too far into the head, it will be impossible to adjust the clearance, and the cylinder head must be replaced. Do not turn the cutter counterclockwise or drop it against the seat, or it will be dulled.

(1) Seat Width
 (2) Cutter

(A) 30° (0.53 rad.)
 (B) 45° (0.79 rad.)

W1028805

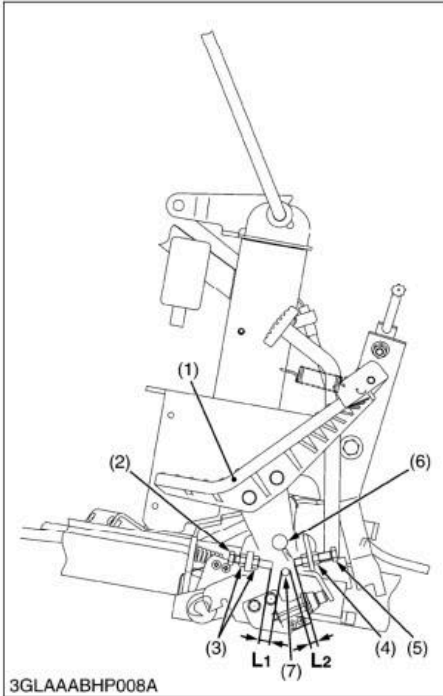

Pedal Stopper (Adjusting Maximum Forward and Reverse Travelling Speed)

NOTE

- This adjustment should be performed after completing the adjustment of neutral.

[Forward Operation]

1. Loosen the lock nut (3) and screw back the adjusting screw (2).
2. Lightly depress the pedal (1) forward to the stroke end.
3. Screw in the adjusting screw (2) until it touches the pedal.
4. Then further screw in the adjusting screw (2) 1/2 turn, and tighten the lock nut (3).

(Reference)

T1570

- Clearance "L1" (when the pedal is in neutral) : 9.5 mm (0.37 in.)

T1670 · T1770 · T1870

- Clearance "L1" (when the pedal is in neutral) : 8 mm (0.31 in.)

(Reference)

T1570

- Clearance "L2" (when the pedal is in neutral) : 4.5 mm (0.18 in.)

T1670 · T1770 · T1870

- Clearance "L2" (when the pedal is in neutral) : 12 mm (0.47 in.)

(1) Speed Change Pedal

(2) Adjusting Screw

(3) Lock Nut

(4) Lock Nut

(5) Adjusting Screw

(6) Fulcrum

(7) Speed Change Pedal Pin

F : Forward

R : Reverse

W1011484

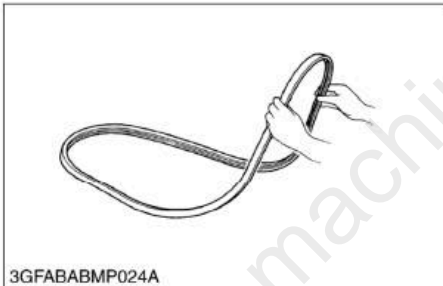

Checking HST Belt

1. Check to see the HST belt.
2. Replace the HST belt with a new one, if there is found surface split at more than 3 positions.

W1012039

[2] STARTING SYSTEM

(1) Checking

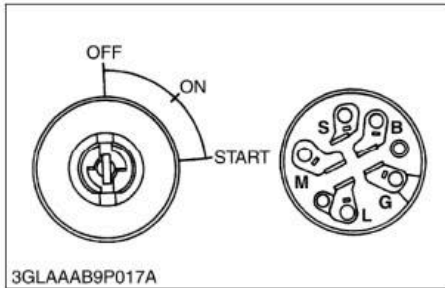
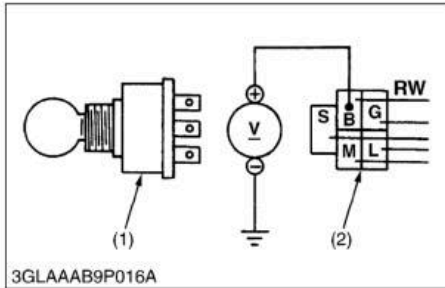

Main Switch

1) Connector Voltage

1. Turn the main switch off.
2. Open the bonnet and disconnect the 5P connector (2) from the main switch (1).
3. Measure the voltage with a voltmeter across the connector **B** terminal and chassis.
4. If the voltage differs from battery voltage, the wiring harness is faulty.

Voltage (B terminal-Chassis)	Factory spec.	Battery voltage
------------------------------	---------------	-----------------

2) Terminal Continuity

1. Remove the main switch from the main panel.
2. Measure the resistance with an ohmmeter across terminals when the main switch is set at “OFF” position.
3. Measure the resistance with an ohmmeter across terminals when the main switch is set at “ON” position.
4. Measure the resistance with an ohmmeter across terminals when the main switch is set at “START” position.
5. If the resistance values specified below are not indicated, the main switch is faulty.

Main switch is set at “OFF” position.

	G terminal	M terminal	B terminal	L terminal	S terminal
G terminal		Continuity	Infinity	Infinity	Infinity
M terminal	Continuity		Infinity	Infinity	Infinity
B terminal	Infinity	Infinity		Infinity	Infinity
L terminal	Infinity	Infinity	Infinity		Infinity
S terminal	Infinity	Infinity	Infinity	Infinity	

Main switch is set at “ON” position.

	G terminal	M terminal	B terminal	L terminal	S terminal
G terminal		Infinity	Infinity	Infinity	Infinity
M terminal	Infinity		Infinity	Infinity	Infinity
B terminal	Infinity	Infinity		Continuity	Infinity
L terminal	Infinity	Infinity	Continuity		Infinity
S terminal	Infinity	Infinity	Infinity	Infinity	

Main switch is set at “START” position.

	G terminal	M terminal	B terminal	L terminal	S terminal
G terminal		Continuity	Infinity	Infinity	Infinity
M terminal	Continuity		Infinity	Infinity	Infinity
B terminal	Infinity	Infinity		Continuity	Continuity
L terminal	Infinity	Infinity	Continuity		Continuity
S terminal	Infinity	Infinity	Continuity	Continuity	

(1) Main Switch

(2) 5P Connector

W1020774

Full Version Available

Kubota T1770 Lawn Tractor Workshop Manual

This is a short preview. The complete manual contains all chapters, wiring diagrams, torque specifications and full service procedures.

VIEW THE FULL MANUAL

<https://machinecatalogic.com/kubota-t1770-lawn-tractor-workshop-manual/>