

# WSM

---

WORKSHOP MANUAL  
**WALK BEHIND MOWER**

**W821SC-AU, W821S-AU,  
W819P-AU**

---

**Кубота**

## **2 REAPING PORTION**

machinecatalogic.com

## Maintenance

### OIL RECOMMENDATIONS

We recommend use of Kohler oils for best performance. Other high-quality detergent oils (including synthetic) of API (American Petroleum Institute) service class SJ or higher are acceptable. Select viscosity based on air temperature at time of operation as shown in table below.

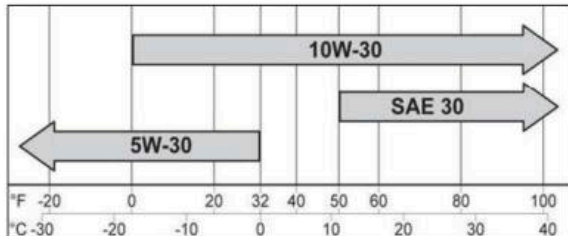

### FUEL RECOMMENDATIONS

	<b>WARNING</b> Explosive Fuel can cause fires and severe burns. Do not fill fuel tank while engine is hot or running.
Gasoline is extremely flammable and its vapors can explode if ignited. Store gasoline only in approved containers, in well ventilated, unoccupied buildings, away from sparks or flames. Spilled fuel could ignite if it comes in contact with hot parts or sparks from ignition. Never use gasoline as a cleaning agent.	

NOTE: E15, E20 and E85 are NOT approved and should NOT be used; effects of old, stale or contaminated fuel are not warrantable.

Fuel must meet these requirements:

- Clean, fresh, unleaded gasoline.
- Octane rating of 87 (R+M)/2 or higher.
- Research Octane Number (RON) 90 octane minimum.
- Gasoline up to 10% ethyl alcohol, 90% unleaded is acceptable.
- Methyl Tertiary Butyl Ether (MTBE) and unleaded gasoline blend (max 15% MTBE by volume) are approved.
- Do not add oil to gasoline.
- Do not overfill fuel tank.
- Do not use gasoline older than 30 days.

### STORAGE

If engine will be out of service for 2 months or more follow procedure below.

1. Add Kohler PRO Series fuel treatment or equivalent to fuel tank. Run engine 2-3 minutes to get stabilized fuel into fuel system (failures due to untreated fuel are not warrantable).
2. Change oil while engine is still warm from operation. Remove spark plug(s) and pour about 1 oz. of engine oil into cylinder(s). Replace spark plug(s) and crank engine slowly to distribute oil.
3. Disconnect negative (-) battery cable.
4. Store engine in a clean, dry place.

## TROUBLESHOOTING GUIDE

When troubles occur, be sure to check simple causes which, at first, may seem too obvious to be considered. For example, a starting problem could be caused by an empty fuel tank.

Some general common causes of engine troubles are listed below and vary by engine specification. Use these to locate causing factors.

### Engine Cranks But Will Not Start

---

- Battery connected backwards.
- Blown fuse.
- Carburetor solenoid malfunction.
- Choke not closing.
- Clogged fuel line or fuel filter.
- Diode in wiring harness failed in open circuit mode.
- DSAI or DSAM malfunction.
- Empty fuel tank.
- Faulty electronic control unit.
- Faulty ignition coil(s).
- Faulty spark plug(s).
- Fuel pump malfunction-vacuum hose clogged or leaking.
- Fuel shut-off valve closed.
- Ignition module(s) faulty or improperly gapped.
- Insufficient voltage to electronic control unit.
- Interlock switch is engaged or faulty.
- Key switch or kill switch in OFF position.
- Low oil level.
- Quality of fuel (dirt, water, stale, mixture).
- SMART-SPARK™ malfunction.
- Spark plug lead(s) disconnected.

### Engine Starts But Does Not Keep Running

---

- Faulty carburetor.
- Faulty cylinder head gasket.
- Faulty or misadjusted choke or throttle controls.
- Fuel pump malfunction-vacuum hose clogged or leaking.
- Intake system leak.
- Loose wires or connections that intermittently ground ignition kill circuit.
- Quality of fuel (dirt, water, stale, mixture).
- Restricted fuel tank cap vent.

### Engine Starts Hard

---

- Clogged fuel line or fuel filter.
- Engine overheated.
- Faulty ACR mechanism.
- Faulty or misadjusted choke or throttle controls.
- Faulty spark plug(s).
- Flywheel key sheared.
- Fuel pump malfunction-vacuum hose clogged or leaking.
- Interlock switch is engaged or faulty.
- Loose wires or connections that intermittently ground ignition kill circuit.
- Low compression.
- Quality of fuel (dirt, water, stale, mixture).
- Weak spark.

### Engine Will Not Crank

---

- Battery is discharged.
- Faulty electric starter or solenoid.
- Faulty key switch or ignition switch.
- Interlock switch is engaged or faulty.
- Loose wires or connections that intermittently ground ignition kill circuit.
- Pawls not engaging in drive cup.
- Seized internal engine components.

### Engine Runs But Misses

---

- Carburetor adjusted incorrectly.
- Engine overheated.
- Faulty spark plug(s).
- Ignition module(s) faulty or improperly gapped.
- Incorrect crankshaft position sensor air gap.
- Interlock switch is engaged or faulty.
- Loose wires or connections that intermittently ground ignition kill circuit.
- Quality of fuel (dirt, water, stale, mixture).
- Spark plug lead(s) disconnected.
- Spark plug lead boot loose on plug.
- Spark plug lead loose.

### Engine Will Not Idle

---

- Engine overheated.
- Faulty spark plug(s).
- Idle fuel adjusting needle(s) improperly set.
- Idle speed adjusting screw improperly set.
- Inadequate fuel supply.
- Low compression.
- Quality of fuel (dirt, water, stale, mixture).
- Restricted fuel tank cap vent.

### Engine Overheats

---

- Cooling fan broken.
- Excessive engine load.
- Fan belt failed/off.
- Faulty carburetor.
- High crankcase oil level.
- Lean fuel mixture.
- Low cooling system fluid level.
- Low crankcase oil level.
- Radiator, and/or cooling system components clogged, restricted, or leaking.
- Water pump belt failed/broken.
- Water pump malfunction.

### Engine Knocks

---

- Excessive engine load.
- Hydraulic lifter malfunction.
- Incorrect oil viscosity/type.
- Internal wear or damage.
- Low crankcase oil level.
- Quality of fuel (dirt, water, stale, mixture).

# Disassembly/Inspection and Service

## Cylinder Head Components

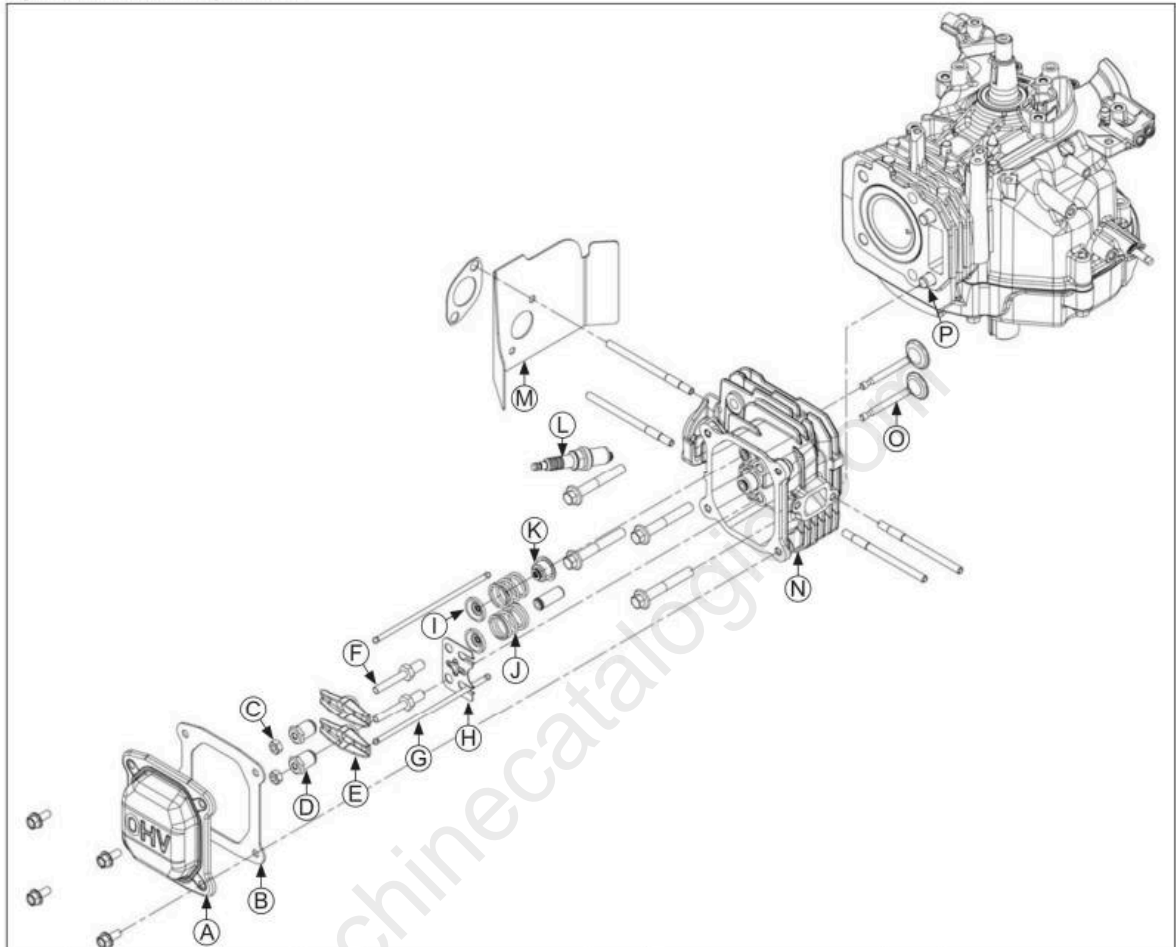

A	Valve Cover	B	Gasket	C	Jam Nut	D	Rocker Arm Pivot
E	Rocker Arms	F	Rocker Arm Stud	G	Push Rod	H	Push Rod Guide Plate
I	Valve Keeper	J	Valve Spring	K	Intake Valve Seal	L	Spark Plug
M	Baffle	N	Cylinder Head	O	Valve	P	Dowel Pin

### Remove Valve Cover

1. Remove screws from valve cover.
2. Remove cover and gasket.

### Remove Jam Nuts and Rocker Arm Pivots

Use a socket and wrench to remove jam nuts and rocker arm pivots from rocker studs.

### Remove Rocker Arms

Noting orientation, lift rocker arms off rocker studs.

### Remove Push Rods

Remove push rods and mark them for reinstallation.

### Remove Rocker Studs

Unscrew and remove rocker studs from cylinder head.

### Remove Guide Plate

1. Remove guide plate from rocker studs.
2. Note orientation of guide plate (tabs down) for use during reassembly.

## Full Version Available

Kubota W819P-AU Walk Behind Mower Workshop Manual

This is a short preview. The complete manual contains all chapters, wiring diagrams, torque specifications and full service procedures.

[VIEW THE FULL MANUAL](#)