

WSM

WORKSHOP MANUAL

Z231BR-AU,
Z231KH-AU,
Z251BR-AU, Z251KH-AU

Kubota

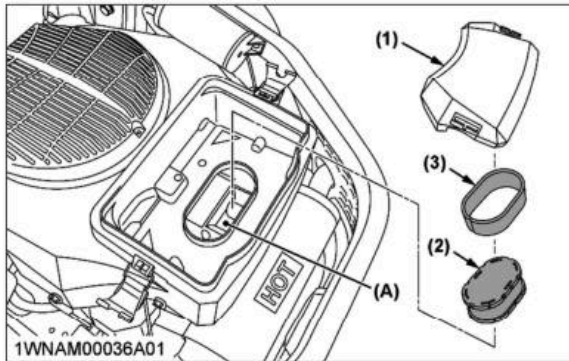

- (1) Air cleaner cover (A) Air intake
(2) Air cleaner element
(3) Precleaner

- Wash the precleaner in warm water with detergent. Rinse the precleaner thoroughly until all traces of detergent are eliminated. Squeeze out excess water. (do not wring.) Allow the precleaner to air dry.
- Saturate the precleaner with new engine oil. Squeeze out all excess oil.
- Reinstall the precleaner over the paper element and install in air intake.
- Reinstall the air cleaner cover and secure with the 2 latches.

2.2 Cleaning air cleaner element (Z231BR-AU, Z251BR-AU)

Every 100 hours of operation or annually replace the paper element. Check every 25 hours of operation. (More often under extremely dusty or dirty conditions.)

Z231BR-AU

- Loosen the air cleaner cover knobs and remove the air cleaner cover.

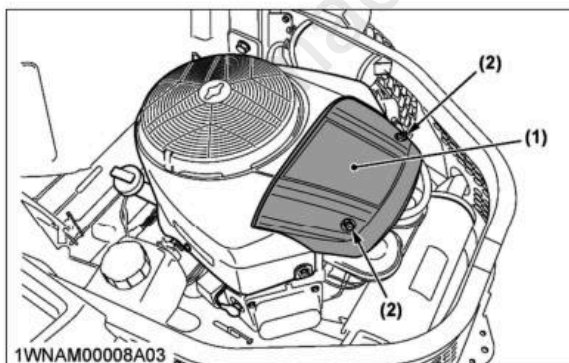

- (1) Air cleaner cover
(2) Air cleaner cover knob

- Remove air cleaner element with precleaner.

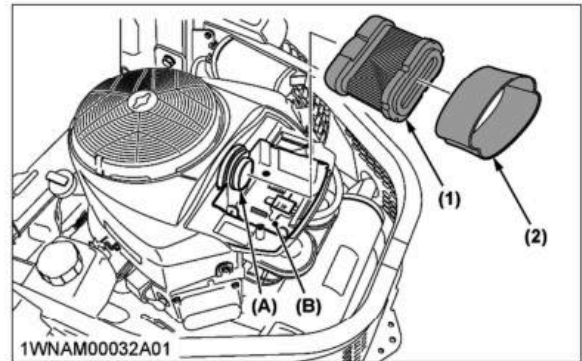

- (1) Air cleaner element (A) Air intake
(2) Precleaner (B) Base

- Remove the precleaner from the paper element.
- Gently tap the paper element to dislodge dirt. Do not wash the paper element or use pressurized air, as this will damage the element. Replace a dirty, bent, or damaged element with a genuine part. Handle the new element carefully; do not use if the sealing surfaces are bent or damaged.
- Clean the air cleaner base as required and check condition.
- Reinstall the precleaner over the paper air cleaner element and install it on the base.
- Reinstall the air cleaner cover and secure it with 2 knobs.

NOTE

- Operating the engine with loose or damaged air cleaner components could allow unfiltered air into the engine causing premature wear and failure.

Z251BR-AU

- Loosen the air cleaner cover knobs and remove the air cleaner cover.

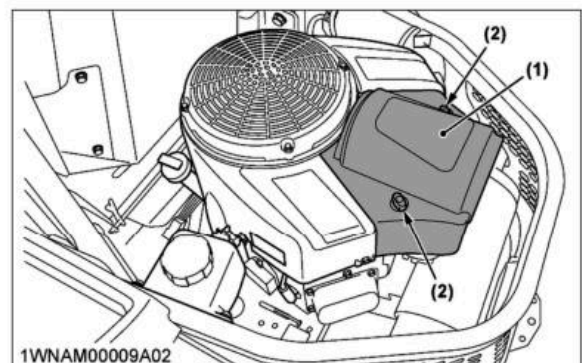

- (1) Air cleaner cover
(2) Air cleaner cover knob

- Open the latch and remove the air cleaner element.

2. Servicing specifications for engine

Refer to "Common Specifications" and "Standard and Reject Dimensions" at Section 1 General Information of GH731V-1, GH733V-1 Briggs and Stratton Engine Service Manual or GH736V, GH750V Kohler Engine Service Manual.

machinecatalogic.com

2. Servicing specifications for transaxle

Item		Service specification	Service limit
HST neutral at maximum engine speed	Rear wheel rotation	Rear wheel does not rotate with the motion control lever in neutral lock	—
Maximum speed at maximum engine rpm	Rear wheel rotation	118 to 138 rpm 12 to 13 km/h 7.4 to 8.6 mph	Difference between L.H. and R.H. Less than 2 rpm 0.2 km/h (0.1 mph)
Motion control lever alignment	Gap	0 to 2 mm 0 to 0.08 in.	—

machinecatalogic.com

3.2 Electrical circuit of gauge system

The gauge system consists of a hour meter (19), and oil switch.
Current flows from the battery (17) to the main switch (7), and then to the hour meter.

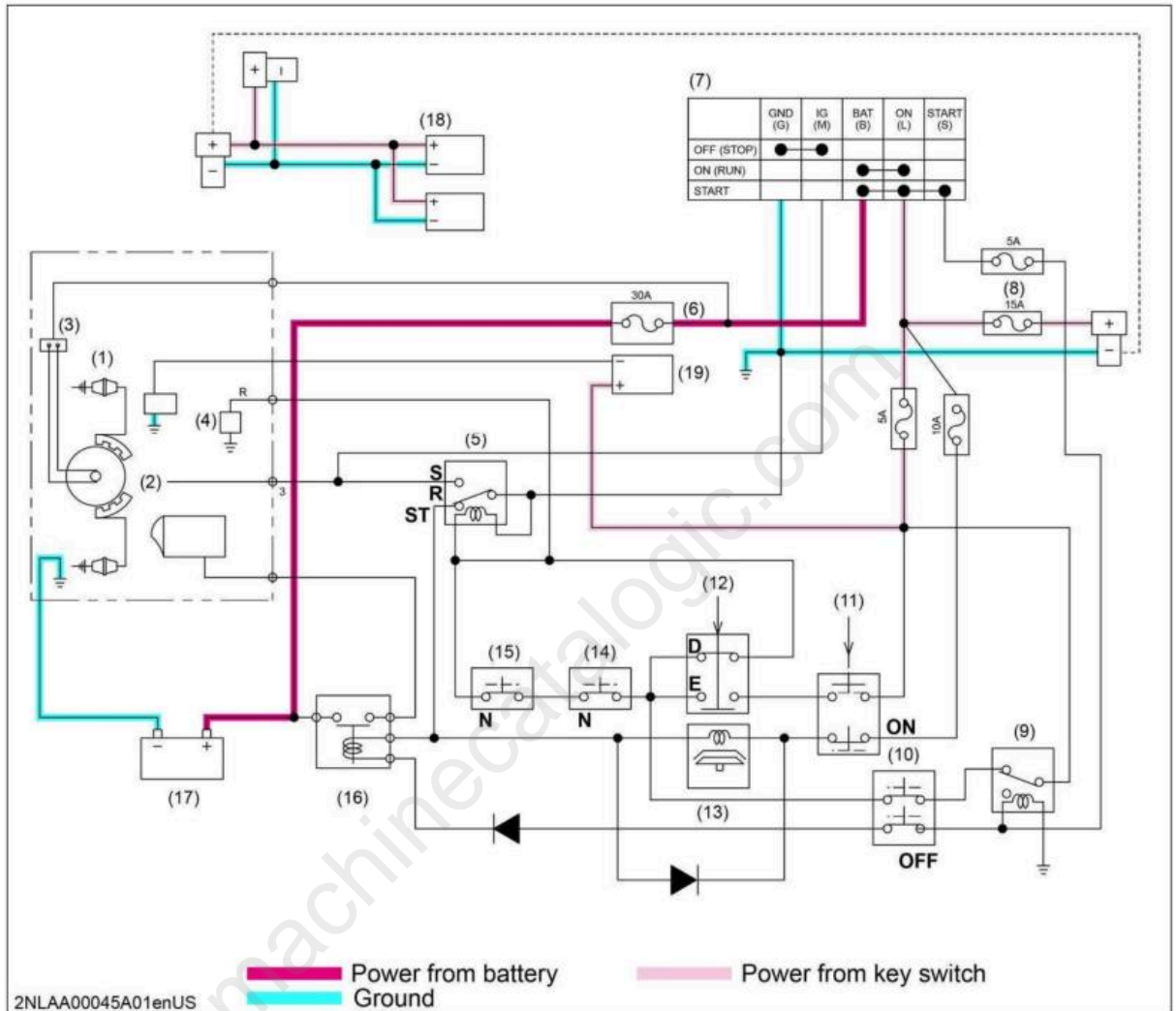

- | | | | |
|--------------------|-------------------|---|-----------------|
| (1) Spark plug | (8) Fuse | (14) Motion control lever switch (L.H.) | (19) Hour meter |
| (2) Ignition coil | (9) Seat relay | (15) Motion control lever switch (R.H.) | S: Stop |
| (3) Regulator | (10) Seat switch | (16) Starter solenoid | R: Run |
| (4) Fuel solenoid | (11) PTO switch | (17) Battery | ST: Start |
| (5) Stop relay | (12) Brake switch | (18) Headlights (Z231KH-AU, Z251KH-AU) | N: Neutral |
| (6) Slow blow fuse | (13) PTO clutch | | D: Disengage |
| (7) Main switch | | | E: Engage |

Full Version Available

Kubota Z231KH-AU Zero Turn Mower Workshop Manual

This is a short preview. The complete manual contains all chapters, wiring diagrams, torque specifications and full service procedures.

[VIEW THE FULL MANUAL](#)