

# WSM

---

WORKSHOP MANUAL

Z411KW-AU,  
Z421KW-AU,  
Z412KW-AU, Z422KW-AU

---

**Kubota**

## 2. GENERAL

## CHECK AND MAINTENANCE 4. Check points of every 100 hours

4. Check spark plug gap with gap gauge.

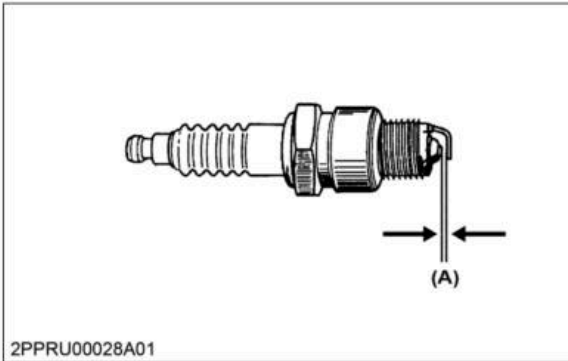

2PPRU00028A01

(A) 0.7 to 0.8 mm (0.028 to 0.031 in.)

5. Reinstall the spark plug into the cylinder head.

Tightening torque	Spark plug	22 N · m 2.2 kgf · m 16 lbf · ft
-------------------	------------	--

## 4.4 Checking fuel lines and fuel filter

### WARNING

To avoid serious injury or death:

- Be sure to stop the engine and remove the key when attempting to make the following checks and changes.
- Never fail to check the fuel lines periodically. The fuel lines are subject to wear and aging. Fuel may leak out onto the running engine, causing a fire.

### IMPORTANT

- When the fuel line is disconnected for maintenance or repair, close both ends of the fuel line with a piece of clean cloth or paper to prevent dust and dirt from entering.
- Particular care must be taken not to admit dust and dirt into the fuel pump. Entrance of dust and dirt causes malfunction of the fuel pump.

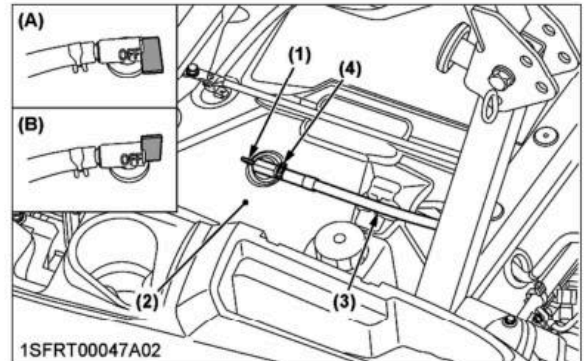

1SFRT00047A02

- |                |                 |
|----------------|-----------------|
| (1) Fuel valve | (4) Pipe clamp  |
| (2) Fuel tank  | (A) Close (Off) |
| (3) Fuel line  | (B) Open        |

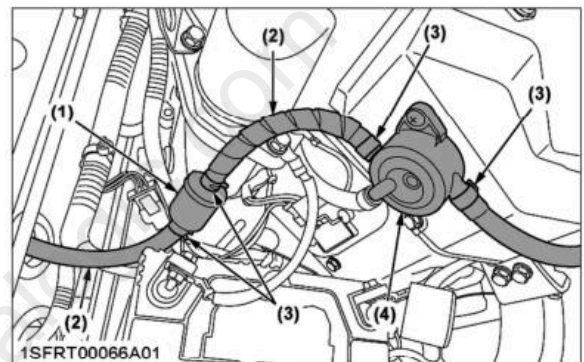

1SFRT00066A01

- |                 |                |
|-----------------|----------------|
| (1) Fuel filter | (3) Pipe clamp |
| (2) Fuel line   | (4) Fuel pump  |

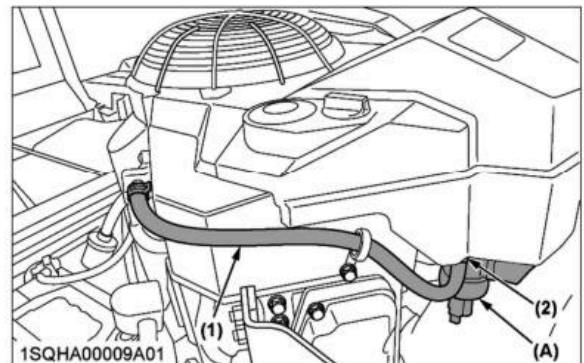

1SQHA00009A01

- |                |                |
|----------------|----------------|
| (1) Fuel line  | (A) Carburetor |
| (2) Pipe clamp |                |

The fuel line is made of rubber and ages regardless of service period.

1. Check the fuel line, clamps and fuel filter.
2. If those parts are found damaged or deteriorated, replace them.

1. Remove the muffler shield (1).



(1) Muffler shield

2. Disconnect the electric clutch harness (5) from the wire harness.
3. Remove the mower belt (3) from the electric clutch (2).
4. Remove the PTO clutch stopper (4).
5. Remove the electric clutch.

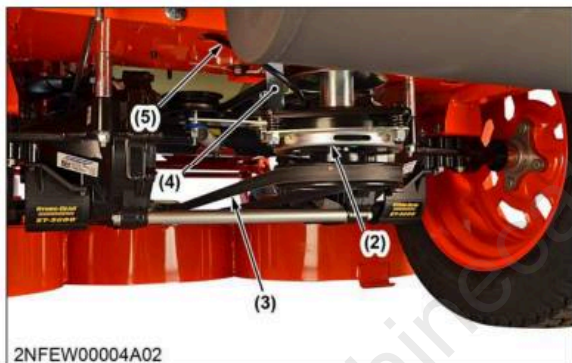

(2) Electric clutch  
 (3) Mower belt  
 (4) Clutch stopper  
 (5) Electric clutch harness

(When reassembling)

■ IMPORTANT

- Install the PTO clutch stopper into the slot (A), next to the wire harness.

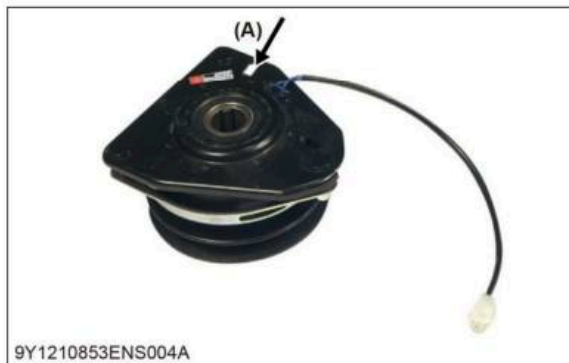

(A) Slot

- **Make sure to install the spring plate (6) with the cup face up.**

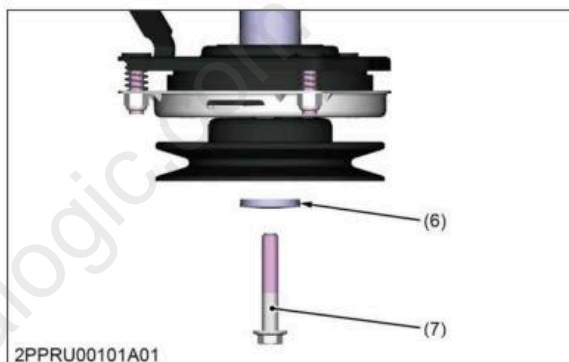

(6) Spring plate  
 (7) Flange bolt

- **Tighten to the specified tightening torque.**
- **As a general rule, use the low end of the torque spec. on fasteners when reassembling.**

Tightening torque	Flange bolt (Electric clutch)	62.8 to 72.5 N·m 6.41 to 7.39 kgf·m 46.3 to 53.5 lbf·ft
-------------------	-------------------------------	---

5.1.4 Removing HST pulley (Z411KW, Z421KW)

**⚠ WARNING**

To avoid serious injury or death:

- **Be careful when you remove the HST pulley. When tension is removed from the belt, the pulley will fall from its operating position.**

Tools required

- LOCTITE C5-A Copper Based Anti-Seize Lubricant or equivalent

4. TRANSAXLE

(When reassembling)

■ IMPORTANT

- Attach the HST tension spring (3) with the long hook (L) to the tension pulley (4).

5.1.3 Loosening HST belt (Z411KW, Z421KW, Z412KW, Z422KW)

■ NOTE

- The Z411KW and Z421KW manufactured after December 2020 will be equipped with the same HST tension pulley mechanism as the Z412KW and Z422KW. Please see the production identification number (PIN) for this information.

1. Remove the flange nut and belt retainer (1).
2. Remove the HST tension spring (4).

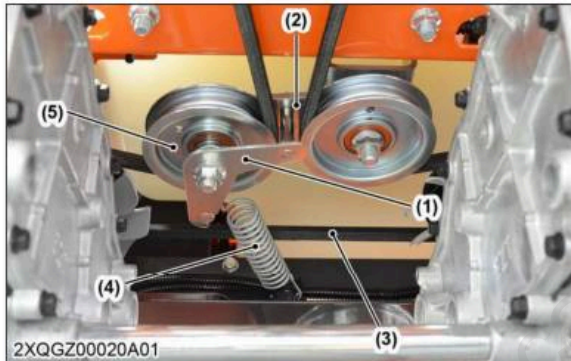

- |                     |                        |
|---------------------|------------------------|
| (1) Belt retainer   | (4) HST Tension spring |
| (2) HST tension arm | (5) Tension pulley     |
| (3) HST belt        |                        |

3. Check that no tension is on the HST belt (3).

(When reassembling)

■ IMPORTANT

- Attach the HST tension spring (4) with the long hook (L) to the tension pulley (5) away from the belt retainer pin (9) as shown. Illustration view from bottom side of unit.

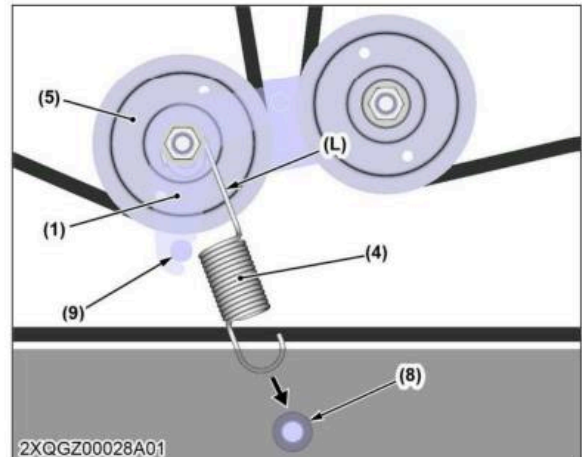

- |                        |                       |
|------------------------|-----------------------|
| (1) Belt retainer      | (9) Belt retainer pin |
| (4) HST tension spring | (L) Long hook         |
| (5) Tension pulley     |                       |
| (8) Spring boss        |                       |

- Tighten to the specified tightening torque.

Tightening torque	Flange nut (Belt retainer)	77.4 to 90.2 N·m 7.90 to 9.19 kgf·m 57.1 to 66.5 lbf·ft
-------------------	----------------------------	---

5.1.4 Disconnecting rods

1. Remove the speed change bolt (8), flange nut (9) and disconnect the control rod (7) from the control arm (6).

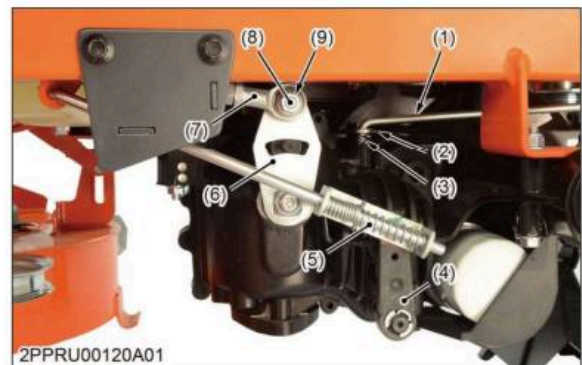

- |                |                       |
|----------------|-----------------------|
| (1) Bypass rod | (6) Control arm       |
| (2) Bypass arm | (7) Control rod       |
| (3) Rue ring   | (8) Speed change bolt |
| (4) Brake arm  | (9) Flange nut        |
| (5) Brake rod  |                       |

2. Remove the split pin (10) and disconnect the brake rod (5) from the brake arm (4).
3. Remove the rue ring (3) and disconnect the bypass rod (1) from the bypass arm (2).

### 3. Checking and adjusting

#### 3.1 Battery

##### 3.1.1 Checking battery voltage

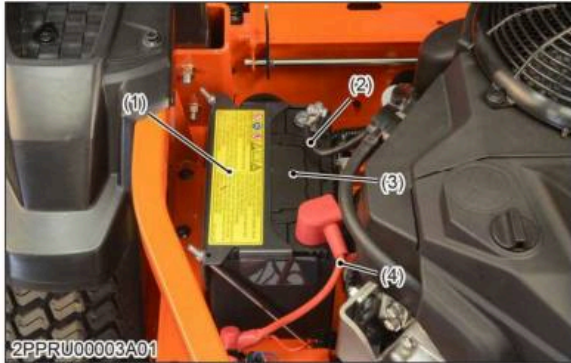

- (1) Battery holder
- (2) Negative cable
- (3) Battery
- (4) Positive cable

1. Stop the engine and turn the main switch to the off position.
2. Connect the COM (-) lead of the voltmeter to the battery's negative terminal post and the (+) lead to the positive terminal post, and measure the battery voltage.
3. If the battery voltage is less than the service specification, check the battery specific gravity and recharge the battery.

Battery voltage	Service specification	More than 12 V
-----------------	-----------------------	----------------

##### 3.1.2 Checking battery terminal connection

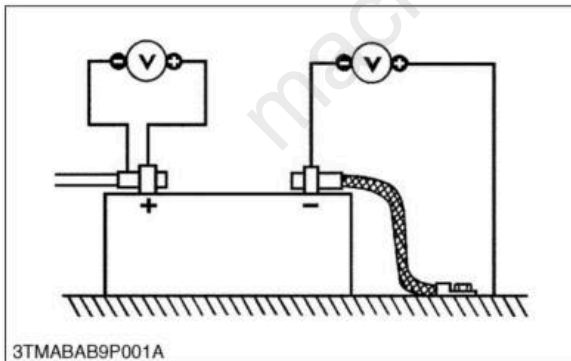

1. Turn the main switch to the on position.
2. Measure the voltage with a voltmeter across the battery's positive terminal post and the cable terminal, and the voltage across the battery's negative terminal post and the chassis.

3. If the measurement exceeds the service specification, clean the battery terminal posts and cable clamps, and tighten them firmly.

Potential difference	Service specification	Less than 0.1 V
----------------------	-----------------------	-----------------

##### 3.1.3 Checking battery specific gravity

**NOTE**

- Hold the hydrometer tube vertical without removing it from the electrolyte.
- Do not suck too much electrolyte into the tube.
- Allow the float to move freely and hold the hydrometer at eye level.
- The hydrometer reading must be taken at the highest electrolyte level.

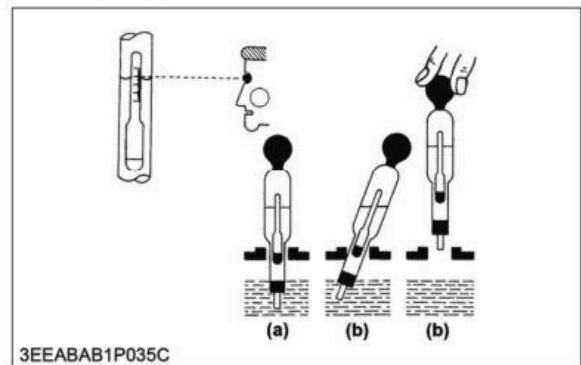
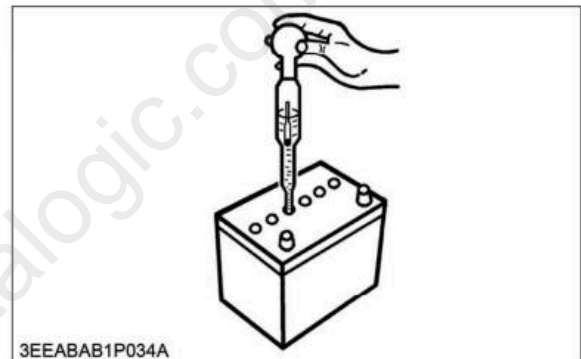

- (a) Correct
- (b) Incorrect

1. Check the specific gravity of the electrolyte in each cell with a hydrometer.

# Full Version Available

Kubota Z422KW-AU Zero Turn Mower Workshop Manual

This is a short preview. The complete manual contains all chapters, wiring diagrams, torque specifications and full service procedures.

[VIEW THE FULL MANUAL](#)