

WSM

WORKSHOP MANUAL ZERO TURN MOWER

ZD18(F) ZD21(F)
ZD25F ZD28(F)

Kubota

Replacing Valve Guide

(When removing)

1. Press out the used valve guide using a valve guide replacing tool.

(When installing)

1. Clean a new valve guide and valve guide bore, and apply engine oil to them.
2. Press in a new valve guide using a valve guide replacing tool.
3. Ream precisely the I.D. of the valve guide to the specified dimension.

Valve guide I.D. (Intake and exhaust)	Factory spec.	D722	6.010 to 6.025 mm
		D782	0.23661 to 0.23720 in.
		D1105	7.010 to 7.025 mm 0.27599 to 0.27657 in.

IMPORTANT

- Do not hit the valve guide with a hammer during replacement.

- (1) Intake Valve Guide
(2) Exhaust Valve Guide

- (A) When Removing
(B) When Installing

W10314690

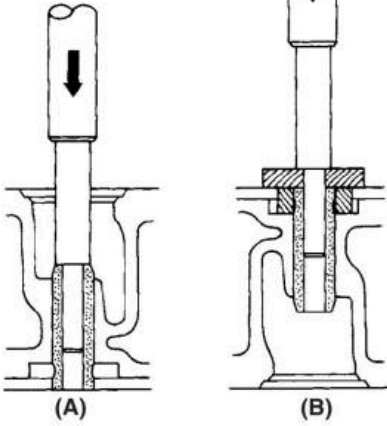

E01940EN09301

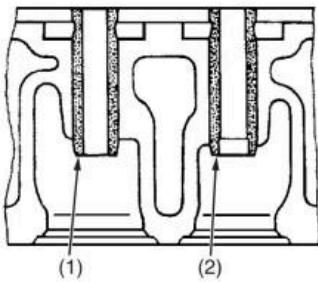

T15040EN05701



T12630EN05600

Valve Seating

1. Coat the valve face lightly with prussian blue and put the valve on its seat to check the contact.
2. If the valve does not seat all the way around the valve seat or the valve contact is less than 70 %, correct the valve seating as follows.
3. If the valve contact does not comply with the reference valve, replace the valve or correct the contact of valve seating.

- (1) Correct
(2) Incorrect

- (3) Incorrect

W1033143

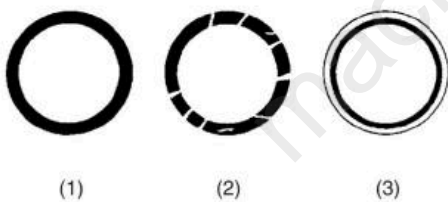

E01940EN06601

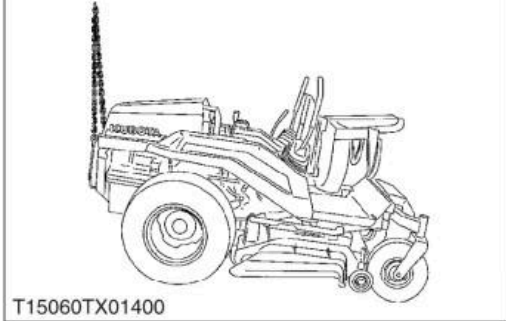

T15060TX01400

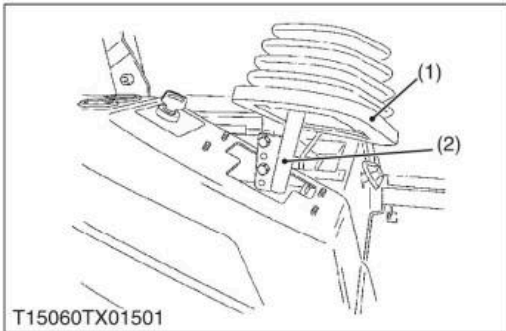

T15060TX01501

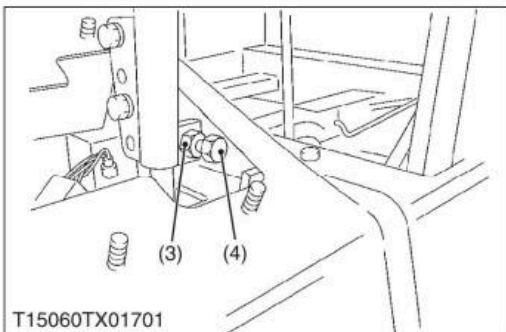

T15060TX01701

CAUTION

To avoid personal injury:

- Park the machine on a hard and level surface.
- If it is necessary to run engine in an enclosed area, use a gas tight exhaust pipe extension to remove the fumes.
- Always try to work in a well-ventilated area.
- Lift up and secure with jack stands or blocking the rear of the machine, do not run the machine while adjusting.
- Do not adjust only one of the following adjustment; exclude "MOTION CONTROL LEVER POSITION".

They are relative each other.

1. Turn key switch to **OFF** position.
2. Apply the parking brake.
3. Set the motion control lever (2) to **Neutral lock** position.
4. Remove the set knobs of seat frame, then raise and latch the seat assembly.
5. Remove the connector from the seat safety switch, then **temporarily** install a jumper wire across the terminals in the connector of the wiring harness.
6. Remove the motion control lever boots (1).
7. Raise the rear of machine and block up so that rear wheel can rotate freely.
8. Start the engine.
9. Move the throttle lever to **Max. speed** position.
10. Push the motion control lever (2) to the front until the speed set bolt (4) comes into contact with the stopper plate.

NOTE

- At this time, the thing that the speed set bolt (4) touches the stopper plate is.
11. Measure the rotations of rear wheel.
 12. If the measurement is not within the factory specifications, loosen the lock nut (3) and adjust the length of speed set bolt (4).

Max. speed: Wheel rotation	Factory spec.	148 to 150 rpm at max. engine speed
-------------------------------	---------------	--

NOTE

- The right and left speed set bolt can be adjusted independently.

- | | |
|--------------------------|--------------------|
| (1) Boot | (3) Lock Nut |
| (2) Motion Control Lever | (4) Speed Set Bolt |

W1014192

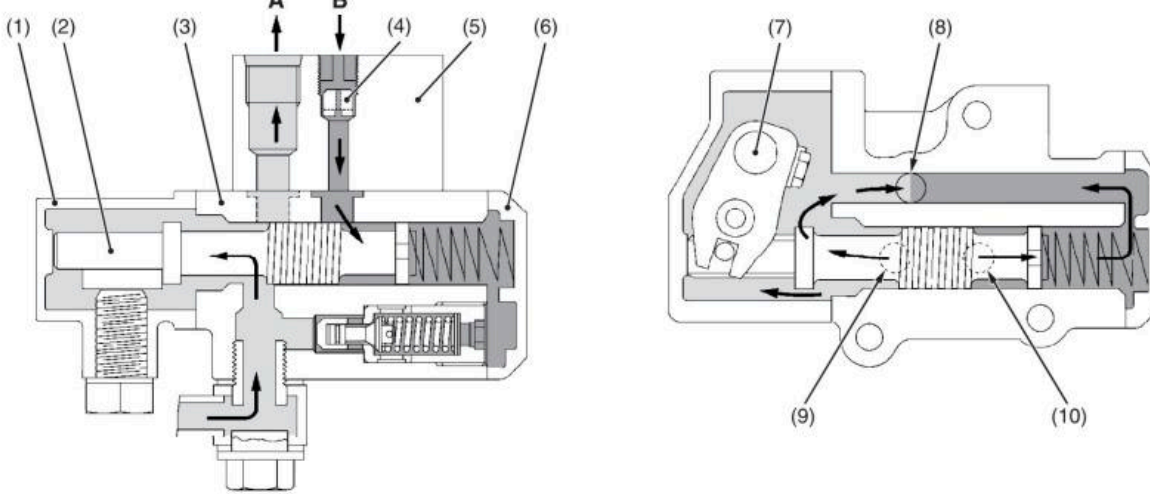

T15060HY00703

- | | | | |
|-----------------|---------------------------|------------------------|---------------------------------------|
| (1) Valve Cover | (5) Control Valve Adaptor | (8) R (Return) Port | A: To Hydrostatic Transmission |
| (2) Spool | (6) Relief Cover | (9) P (Pump) Port | B: From Lift Cylinder |
| (3) Valve Body | (7) Control Lever | (10) C (Cylinder) Port | |
| (4) Orifice | | | |

When the control lever (7) is set to “**DOWN**” position, the spool (2) moves to the left to form a lowering circuit. Therefore, oil in the lift cylinder is forced out by the weight of the mower and returns to the hydrostatic transmission to lower the mower as shown in the figure.

Oil, pressure-fed from the hydraulic pump, goes through the clearance between the valve body (3) and spool (2), and then flows to the hydrostatic transmission through the **R** port (8) and control valve adaptor (5).

4-M6

KiSC issued 09, 2005 A

ZD18(F) · ZD21(F) · ZD28(F), WSM

HYDRAULIC SYSTEM

4. LIFT CYLINDER

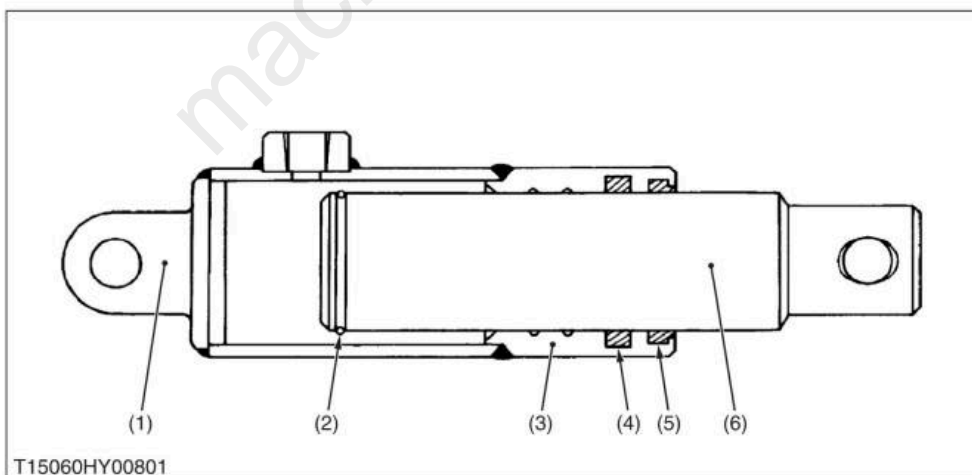

T15060HY00801

- | |
|-------------------|
| (1) Tube End |
| (2) Snap Ring |
| (3) Cylinder Tube |
| (4) Packing |
| (5) Scraper |
| (6) Piston Rod |

W1014031

The lift cylinder consists of the tube end (1), cylinder tube (3), piston rod (6) and other parts as shown in the figure above.

This cylinder is single acting type.

ZD25F, WSM

G GENERAL

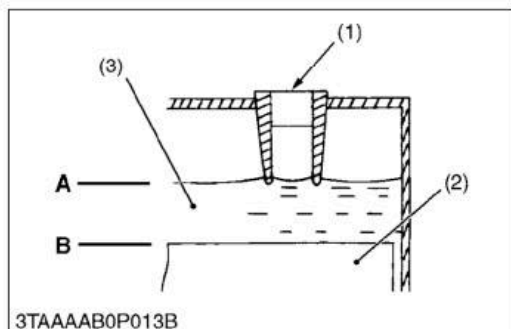

Battery Charging

⚠ DANGER

To avoid serious injury or death:

- When the battery is being activated, hydrogen and oxygen gases in the battery are extremely explosive. Keep open sparks and flames away from the battery at all times, especially when charging the battery.

⚠ CAUTION

- When charging battery, ensure that the vent caps are securely in place (if equipped).
- When disconnecting the cables from the battery, start with the negative terminal first.
When connecting the cables to the battery, start with the positive terminal first.
- Never check battery charge by placing a metal object across the posts.
Use a voltmeter or hydrometer.
(For accessible maintainable type batteries with removable vent caps.)

1. Make sure each electrolyte level is at the bottom of vent wells, if necessary add distilled water in a well-ventilated area.
2. The water in the electrolyte evaporates during recharging. Liquid shortage damages the battery. Excessive liquid spills over and damages the machine body.
3. To slow charge the battery, connect the battery positive terminal to the charger positive terminal and the negative to the negative, then recharge in the standard fashion.
4. A boost charge is only for emergencies. It will partially charge the battery at a higher rate and in a short time.
When using a boost-charged battery, it is necessary to recharge the battery as soon as possible.
Failure to do this will shorten the battery's service life.
5. When the specific gravity of electrolyte reaches 1.27 to 1.29, charge has completed.
6. When exchanging an old battery with new one, use a battery of equal specification shown in "SPECIFICATIONS".
(For non-accessible maintenance-free type batteries.)
Maintenance-free, non-accessible batteries are designed to eliminate the need to add water. Yet the volume of electrolyte above plates may eventually become depleted due to abnormal conditions such as high heat or improper regulator setting. Use a voltmeter to check the state of charge. (See reference chart to determine if charging is necessary.)

Battery voltage	Reference state of charge
12.6	100 % (Full charge)
12.4	75 %
12.2	50 %
12.0	25 %
11.8	0 %

- (1) Vent well
(2) Separator
(3) Electrolyte

(A) Highest Level
(B) Lowest Level

Full Version Available

Kubota ZD25F Zero Turn Mower Workshop Manual

This is a short preview. The complete manual contains all chapters, wiring diagrams, torque specifications and full service procedures.

VIEW THE FULL MANUAL

<https://machinecatalogic.com/kubota-zd25f-zero-turn-mower-workshop-manual/>