

WSM

WORKSHOP MANUAL

ZG124E,ZG123S,
ZG127E,ZG127S

Kubota

[5] CHECK POINT OF EVERY 200 HOURS

Checking Hydraulic Hose

CAUTION

To avoid personal injury:

- Be sure to stop the engine, remove the key, and relieve pressure before checking and replacing the hydraulic hose.
- Allow the transmission case to cool down sufficiently; oil can be hot and may cause burns.

Check to see if hydraulic hoses are properly fixed every 200 hours of operation.

1. Check to see that all lines and hose clamps are tight and not damaged.
2. If hoses and clamps are found worn or damaged, replace or repair them at once.

- (1) Hydraulic Hose
(2) Hose Clamp

- (3) Transaxle Fluid Tank

9Y1210968GEG0033US0

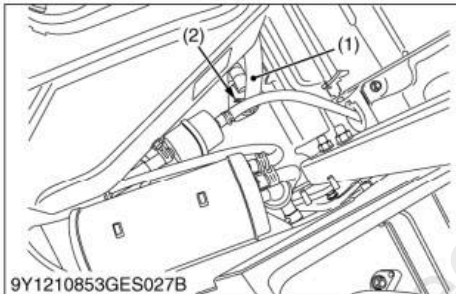
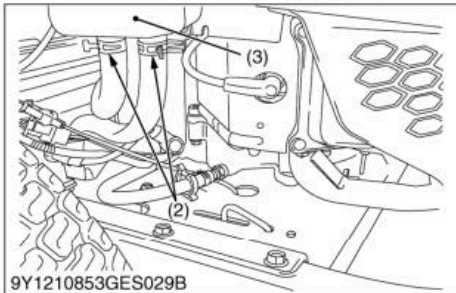
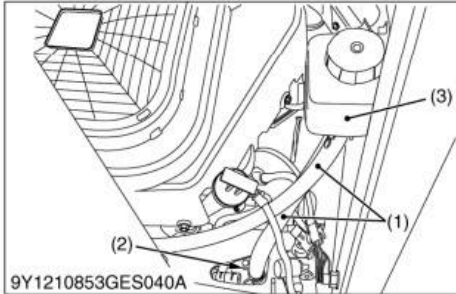

3. TIGHTENING TORQUES

Tightening torques of screws, bolts and nuts on the table below are especially specified.

Refer to also "TORQUES" at

- ZG124E, ZG127E, BRIGGS & STRATTON ENGINE SERVICE MANUAL (SUPPLEMENT).
- ZG123S, ZG127S, KOHLER ENGINE SERVICE MANUAL (SUPPLEMENT).

(For general use screws, bolts and nuts: Refer to "5. TIGHTENING TORQUES" on page G-10.)

Item	N·m	kgf·m	lbf·ft
Flange bolt (for transmission)	62.8 to 72.5	6.4 to 7.4	46.3 to 53.5
Tapping bolt	57.6 to 67.8	5.9 to 6.9	42.5 to 50.0
Bolt rear frame	23.5 to 27.4	2.4 to 2.8	17.4 to 20.2
Thread bolt	20.0 to 23.0	2.0 to 2.3	14.8 to 17.0

9Y1210968ENS0004US0

machinecatalogic.com

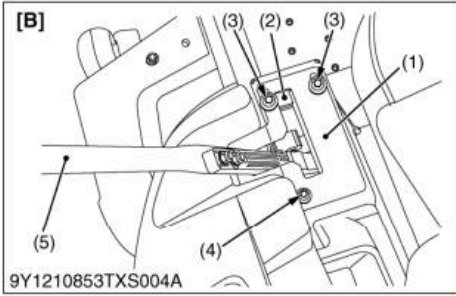
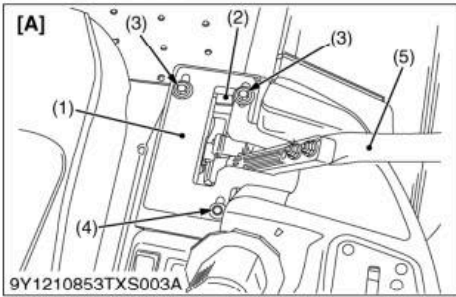

HST Neutral

1. Lift-up and secure with jack stands or blocking the rear of the machine frame.
2. Remove both rear wheels.
3. Start the engine, and run at maximum speed.
4. Place the motion control lever (5) in **"NEUTRAL LOCK"** position.
5. Loosen the three bolts of the guide plate.
Adjust the guide plate position until the rear axle rotation stops.
6. Tighten the rear bolt and place the lever in **"NEUTRAL LOCK"** position. Check that the rear axle does not rotate.
If the axle does not stop rotating, adjust the **"HST NEUTRAL"** again.
7. Adjust the other side **"HST NEUTRAL"** equally.
8. After adjustment, make sure to stop the engine immediately.
9. Push the motion control lever (5) until it contacts the speed adjust plate and reaches the end of its range of motion. Then move the speed adjust plate to 2 to 3 mm backward and tighten two front bolts securely.
10. If at full speed the machine pulls one direction or the other, it is an indication that one wheel is turning faster than the other.
To adjust the condition, proceed as follows:
 - 1) Park the machine on a firm and level surface.
 - 2) Stop the engine.
 - 3) Loosen two front bolts (3) of faster side.
 - 4) Move the speed adjust plate (2) to backward.
 - 5) Tighten two front bolts securely.

Tightening torque	Bolt (front, rear)	23.6 to 27.4 N·m 2.4 to 2.8 kgf·m 17.4 to 20.2 lbf·ft
-------------------	--------------------	---

- (1) Guide Plate
- (2) Speed Adjust Plate
- (3) Bolt (Front)
- (4) Bolt (Rear)
- (5) Motion Control Lever

[A] RH
[B] LH

9Y1210968TXS0005US0

3. CHARGING SYSTEM, HOUR METER, HEAD LIGHT AND PTO CLUTCH

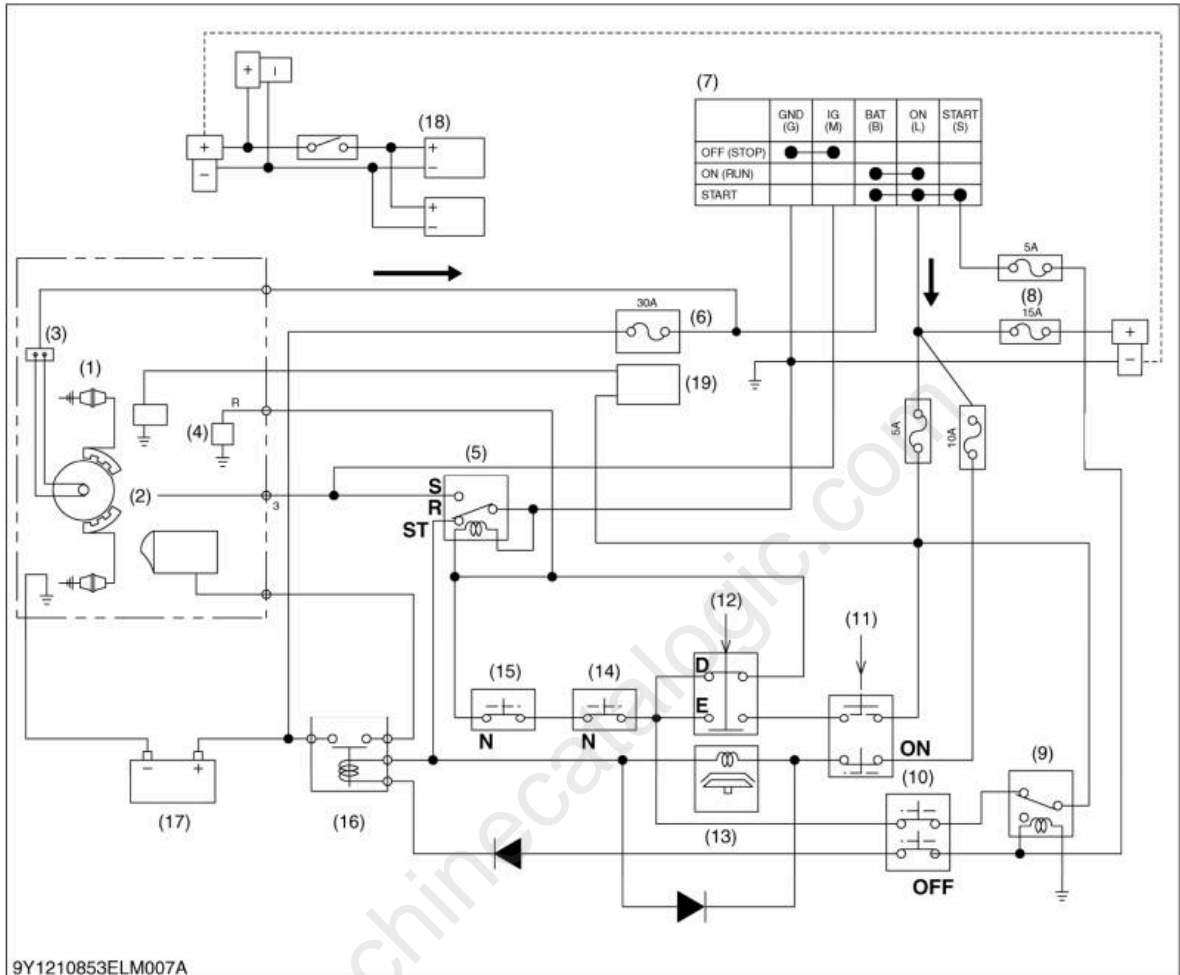

9Y1210853ELM007A

- | | | | |
|--------------------|---------------------------------------|---------------------------------------|---------------------|
| (1) Spark Plug | (9) Starter Relay | (15) Motion Control Lever Switch (RH) | S: Stop |
| (2) Ignition Coil | (10) Seat Switch | (16) Starter Solenoid | R: Run |
| (3) Regulator | (11) PTO Switch | (17) Battery | ST: Start |
| (4) Fuel Solenoid | (12) Brake Switch | (18) Head Light | N: Neutral |
| (5) Starter Relay | (13) PTO Clutch | (19) Hour Meter | D: Disengage |
| (6) Slow Blow Fuse | (14) Motion Control Lever Switch (LH) | | E: Engage |
| (7) Main Switch | | | OFF: OFF |
| (8) Fuse | | | ON: ON |

The charging system supplies electric power for hour meter (19), head lights (18) and PTO clutch (13).
 The system also charges the battery (17) while the engine runs.
 The system consists of a ignition coil (2), alternator magnets in the flywheel engine and a regulator (3).

9Y1210968ELM0010US0

Full Version Available

Kubota ZG127S Zero Turn Mower Workshop Manual

This is a short preview. The complete manual contains all chapters, wiring diagrams, torque specifications and full service procedures.

[VIEW THE FULL MANUAL](#)